



# GUIDELINES ON HARMONISED SYSTEM CUSTOMS CODES AND NATIONAL STATISTICAL CODES FOR ENERGY-EFFICIENT LIGHTING

# **Guidelines on Harmonized System Customs Codes and National Statistical Codes for Energy-Efficient Lighting**

© 2023 United Nations Environment Programme

ISBN: 978-92-807-4050-9

Job Number: DTI/2548/PA

This publication may be reproduced in whole or in part and in any form for educational or non-profit services without special permission from the copyright holder, provided acknowledgement of the source is made. The United Nations Environment Programme would appreciate receiving a copy of any publication that uses this publication as a source.

No use of this publication may be made for resale or any other commercial purpose whatsoever without prior permission in writing from the United Nations Environment Programme. Applications for such permission, with a statement of the purpose and extent of the reproduction, should be addressed to the Director, Communication Division, United Nations Environment Programme, P.O. Box 30552, Nairobi 00100, Kenya.

### **Disclaimers**

The designations employed and the presentation of the material in this publication do not imply the expression of any opinion whatsoever on the part of the Secretariat of the United Nations concerning the legal status of any country, territory or city or area or its authorities, or concerning the delimitation of its frontiers or boundaries.

Mention of a commercial company or product in this document does not imply endorsement by the United Nations Environment Programme or the authors. The use of information from this document for publicity or advertising is not permitted. Trademark names and symbols are used in an editorial fashion with no intention on infringement of trademark or copyright laws.

The views expressed in this publication are those of the authors and do not necessarily reflect the views of the United Nations Environment Programme. We regret any errors or omissions that may have been unwittingly made.

© Maps, photos and illustrations as specified

Suggested citation: United Nations Environment Programme (2023). Guidelines on Harmonized System Customs Codes and National Statistical Codes for Energy-Efficient Lighting. Nairobi

Production: United Nations Environment Programme's United for Efficiency (U4E)

### **For more information, contact:**

#### **United Nations Environment Programme – United for Efficiency initiative**

Industry and Economy Division

Energy, Climate, and Technology Branch

1 Rue Miollis, Building VII,

75015, Paris FRANCE

Tel: +33 (0)1 44 37 14 50

Fax: +33 (0)1 44 37 14 74

E-mail: [unep-u4e@un.org](mailto:unep-u4e@un.org)

<http://united4efficiency.org/>

## ACKNOWLEDGEMENTS

---

These Harmonized System (HS) Customs Codes and Statistical Codes Guidelines were developed by the United Nations Environment Programme (UNEP) United for Efficiency (U4E) initiative, with funding from the Global Environment Fund.

UNEP-U4E would like to thank the many experts, partners and colleagues who contributed to the development and review of the document.

**Compiled by:** Steven Coyne, UNEP-U4E

**Editing:** Paul Kellett and Soledad Garcia, UNEP-U4E

**Cover design:** David Andrade

---



## ACRONYMS AND ABBREVIATIONS

---

GEF	Global Environment Facility
HS	Harmonized System
IEC	International Electrotechnical Commission
IES	Illuminating Engineering Society
LED	Light Emitting Diode
MVE	Monitoring, Verification, and Enforcement
MRV	Monitoring, Reporting, and Verification
MEPS	Minimum Energy Performance Standards
UNEP	United Nations Environment Programme
U4E	United for Efficiency
WCO	World Customs Organization

# TABLE OF CONTENTS

ACKNOWLEDGEMENTS.....	ii
ACRONYMS AND ABBREVIATIONS .....	iii
ABOUT UNITED FOR EFFICIENCY.....	vii
1 INTRODUCTION .....	1
2 SCOPE OF THESE GUIDELINES .....	3
3 INTRODUCTION TO THE HARMONIZED SYSTEM CODE.....	4
3.1 History .....	4
3.2 Structure.....	5
3.3 HS Code .....	5
3.4 Maintenance and updates of international HS codes.....	9
3.5 National component.....	10
3.6 Use of tariff and statistical codes as part of energy efficient product strategy .....	11
4 COMMODITY CLASSIFICATION.....	14
4.1 Detailed knowledge of the commodity .....	14
4.2 The meaning of classification terms.....	14
4.3 Classification process.....	15
5 HS CODES ASSOCIATED WITH LIGHTING PRODUCTS .....	19
5.1 Overview of amendments to HS codes for lighting.....	19
5.2 Importance to energy efficiency policy and regulation activities .....	19
5.3 Managing changes to HS codes for lighting products in HS2022 .....	20
5.4 National tariff codes for lighting products.....	25
6 IMPORT STATISTICS TO TRACK TRANSFORMATION OF MARKET TO LEDS .....	27
6.1 Market transformation impact on analysis of lamp imports .....	27
6.2 Market transformation impact on import analysis of luminaires.....	29
7 DEVELOPING NATIONAL STATISTICAL CODES .....	31
7.1 Identification of the required data refinement.....	31
7.2 Data refinement for lamps.....	31
7.3 Data refinement for luminaires .....	34
7.4 Data refinement for lamp and luminaire components.....	37
7.5 Example country scenario for statistical code creation to support market sector and lighting product monitoring .....	40
8 Annex A: Chapter numbers and descriptions within Sections of HS2022.....	43
9 Annex B: HS2022 classifications for relevant lighting products .....	48

## LIST OF FIGURES

Figure 1: 10-digit commodity code structure .....	5
Figure 2: Identification of the three groups of paired digits of the international component which makes up the six-digit HS code.....	7
Figure 3: Identification of the two groups of paired digits of the four-digit national component.....	10
Figure 4: Definition of LED light source, from HS2022.....	15
Figure 5: Procedural steps for HS code classification .....	16
Figure 6: Example of procedural steps for determining the HS code for a linear LED tube .....	17
Figure 7: Example of linking LED lamp import statistics when HS codes change .....	21
Figure 8: Example of indoor luminaire import statistics becoming segregated with HS code changes...	21
Figure 9: Examples of lamp types (with HS codes) before and after market transition to energy efficient products .....	27
Figure 10: A single LED lamp HS code replacing many HS codes for older lamp technologies typifying different market sectors.....	28
Figure 11: Import figures for the main lamp types at the six-digit HS code level .....	28
Figure 12: Import figures for refined lamp types, based on tariff codes at the eight-digit level .....	29
Figure 13: HS2017 version - Luminaire types before and after transition to energy efficient products showing no change to HS code.....	30
Figure 14: HS2022 segregation of luminaire types identifying the transition to energy efficient products with a unique HS code for integrated LED products .....	30
Figure 15: Lack of refinement for fluorescent and LED lamp types based on market sectors .....	32
Figure 16: The need for segregation of non-directional (circled in red) from directional (circled in green) and linear lamps (circled in blue) within the six-digit HS codes .....	34
Figure 17: Key components imported for product assembly with their own six-digit HS codes in HS2022 .....	37

## LIST OF TABLES

---

Table 1: An example of non-harmonized commodity categories for vehicles .....	4
Table 2: Listing of Section numbers for referencing commodity category titles and the Chapter numbers within each Section.....	6
Table 3: The separation of Section I (Live Animals; Animal Products) into Chapters .....	7
Table 4: The separation of Chapter 01 (Live Animals) into Headings .....	8
Table 5: The separation of Heading 0101 (Live horses, asses, mules and hinnies) into Subheadings.....	8
Table 6: Example of tariff codes used to differentiate import duty levels .....	11
Table 7: Example of statistical codes used to differentiate commodities .....	12
Table 8: Example of combination of tariff and statistical codes used to differentiate commodities and tariffs.....	13
Table 9: HS codes for lighting products in Section XVI.....	23
Table 10: HS codes for lighting products in Section XX .....	24
Table 11: Pakistan tariff codes for lamps for 2021-2022 (based on HS2017) .....	26
Table 12: Creation of statistical codes for segregation of sector representative lamp types .....	33
Table 13: Examples of representative luminaire types (and HS codes) for different market sectors .....	34
Table 14: Creation of statistical codes for segregation of sector representative indoor luminaire types	36
Table 15: Creation of statistical codes for segregation of sector representative roadway luminaires.....	37
Table 16: Creation of statistical codes for segregation of sector representative roadway luminaires.....	38
Table 17: Statistical code creation for lamps.....	39
Table 18: Statistical code creation for luminaires .....	42
Table 19: HS2022 Chapter 85 Headings with Subheading classifications for relevant lighting products	48
Table 20: HS2022 Chapter 94 Headings with Subheading classifications for relevant lighting products	50



## ABOUT UNITED FOR EFFICIENCY

---

U4E ([united4efficiency.org/](http://united4efficiency.org/)) is a global initiative led by UNEP, supported by leading companies and organizations with a shared interest in transforming markets for lighting, appliances and equipment, by encouraging countries to implement an integrated policy approach to energy-efficient products so as to bring about a lasting, sustainable and cost-effective market transformation.

The approach focuses on the end-user market and targets the five main components of the value chain for an energy-efficient market:

- Standards and regulations.
- Supporting policies, including education, information, and training.
- Market monitoring, verification and enforcement.
- Finance and financial delivery mechanisms, including incentives and public procurement.
- Environmentally sound management and health.

U4E provides countries with tailored technical support through their in-house international experts and specialized partners, to get the most out of countries' electricity by accelerating the widespread adoption of energy-efficient products, allowing monetary savings on consumer electricity bills, helping businesses to thrive through greater productivity, enabling power utilities to meet growing demands for electricity and assisting governments in reaching their economic and environmental ambitions. Currently the initiative is present in more than 30 countries worldwide. Based on each country's circumstances, U4E works with any of the following products: Lighting, Refrigerators, Room Air Conditioners, Electric Motors and Distribution Power Transformers – the five products that together consume over half of the world's electricity. Such support is available at three levels: Global, Regional and National; providing tools and resources and supporting multiple stakeholders on international best practices, regional policy roadmaps and harmonization process recommendations through guidelines and publications, such as energy efficiency Policy Guides, Global Model Regulations Guidelines, Model Public Procurement Specifications and Financing Guidelines. In addition, the initiative provides capacity building and education, policy tools and technical resources which include Country Savings Assessments completed for more than 155 countries showing the significant available financial, environmental, energy, and societal benefits that are possible with a full transition to more energy-efficient electrical products. This growing suite of tools and resources equips policymakers to understand the significant opportunities and the steps needed to start transforming their markets to eco-efficient appliances and equipment.

# 1 INTRODUCTION

---

Many countries are launching Minimum Energy Performance Standards (MEPS) and energy labelling for lighting products in the domestic, commercial, industrial, and public lighting sectors. The scope of these MEPS varies from only non-directional lamps through to all light sources.

Fundamental to the successful implementation of an energy efficient product regulatory programme, which endeavours to transform a market, is the effective monitoring of the quantities of products sold in the market which are within the scope of the regulations, and those which may be included in any future expansion of the MEPS scope. A de facto metric for quantities of products sold in the market in countries that are not major manufacturers of lighting products is the import data from Customs. For countries that are major manufacturers, the local manufacturing quantities are required as well as the import and export data. A critical component of the trade data is the commodity classification system.

Policymakers and regulators involved in energy efficient lighting programmes should be aware of the opportunity for enhanced monitoring of lighting product import data available through the World Customs Organization (WCO)'s Harmonized System classification of commodities. The benefits of this data include: the ability to monitor trends over time for imported lighting products, the application of real data to lighting policy development, and facilitating local monitoring, reporting, and verification (MRV) and monitoring verification and enforcement (MVE) activities.

HS codes are used by governments for a range of purposes: internal taxes, trade policies, monitoring of controlled goods, freight tariffs, quota controls, compilation of national accounts, and economic research and analysis. The focus of this guide is the application of HS codes to lighting products, and the important lighting product-related code updates contained in the latest WCO version, HS2022<sup>1</sup>.

In HS2022, the six-digit international HS codes have been updated to recognise the significant overall market shift to LED lighting technology by providing LED technologies their own distinct product categories. However, most policymakers and regulators will require further refinement of lighting product subcategories to realise the full benefits of the product import data. This is where national codes, an additional four digits appended to the six-digit HS Code, provide an opportunity for separating out all product subgroups that are relevant to evaluating the performance of energy efficient lighting regulatory programmes. For subgroupings, the most pertinent segment of the national component is the National Statistical Code, the last two-digits (9<sup>th</sup> and 10<sup>th</sup>) of the of the 10-digit system. But prior to designing an appropriate national statistical code structure, the existing National Tariff Codes (7<sup>th</sup> and 8<sup>th</sup> digits) will also need to be identified and considered.

This guide details the structure and function of the 10-digit code system in general; both in terms of the six-digit HS code, and the four-digit national code. Using a detailed example, it steps the reader through the process of devising national statistical codes for lighting products relevant to government regulatory programmes, showing how to separate products by technology, application, and market sector. It also shows how the lighting data that arises from these codes can be analysed, including: how product import trends in time may be graphically displayed, and how to handle apparent data discontinuities due to changes in HS code numbering for commodities between HS2022 and previous versions.

---

<sup>1</sup> Available at the World Customs Organization website at:

<https://www.wcoomd.org/en/topics/nomenclature/instrument-and-tools/hs-nomenclature-2022-edition.aspx>

A well-structured set of national statistical codes developed by one country can provide an opportunity for regional harmonisation of such codes amongst trading partners and provide import/export volume data of significant detail for lighting products under government regulatory programmes. The benefits to national and regional interests are clear and encourages the forward planning outlined in this guide to best make use of these symbiotic relationships. Ideally the process of the development of national statistical codes would be undertaken prior to (or concurrently with) the implementation of MEPS by the country's relevant government agency administering energy efficient lighting and appliances regulation (e.g., Department of Energy) and the agency administering commodity import/export statistics (e.g., Bureau of Statistics) to achieve greatest benefit.

## 2 SCOPE OF THESE GUIDELINES

---

All commodities imported into a country must pass through customs. As part of this process, the importer submits an import declaration which includes a classification code for the commodity which assists with identifying it and determining any regulatory control actions required. This classification code is in part harmonized by more than 200 countries under the Harmonized Commodity Description and Coding System (generally referred to as the Harmonized System or simply HS). This comprises of over 5,000 commodity groups, each based on a six-digit code. Each country has the option to use a further four digits (appended to the six digits of the HS code) for nation-specific information. Data on the quantities of trade in and out of a country based on their full 10-digit commodity code is freely available for analysis. Among other purposes, it is extensively used by governments for internal taxes, trade policies, monitoring of controlled goods, freight tariffs, quota controls, compilation of national accounts, and economic research and analysis. The Harmonized System is therefore a universal code for goods and is an indispensable tool for monitoring international trade of goods within scope of a regulatory framework.

The coding system is revised every five years. The current version is HS2022, which replaced the previous version (HS2017) and came into effect on January 1, 2022. Significant changes have been included in the HS2022 system in relation to lighting commodities. Refinement of light-emitting diode (LED) product categories has been implemented, along with improved definitions which should facilitate more accurate reporting of commodity types and quantities in the future. This is important for monitoring, reporting and verification (MRV) activities for regulatory programmes and supporting border control of imported products associated with these programmes.

This guide introduces policymakers and regulators of energy efficient lighting programmes to the background, purpose, and function of the Harmonized System, focusing on HS codes for lighting products and the changes made in HS2022 relevant to lighting and LED products.

Included in this document is a general introduction to the development of the current 10-digit commodity code (Section 2.1), with detailed examples of how the six-digit HS codes are structured to reflect product categories at the different levels of the Harmonized System (Section 2.3). Further detail and examples are given on the structure and benefit of the four-digit national codes, and how they provide opportunities to subdivide lighting product categories at tariff and statistical levels tailored to regional needs (Section 2.4). Section 3 of this guide explains how to classify commodities using the six-digit HS code and four-digit national code, with a step-by-step example using an LED lighting product. Section 4 details the lighting-related updates contained within HS2022 and provides examples of how HS code data can be used to analyse trends in commodity trade over time, showing how this can be relevant for energy efficient lighting policy and programme development.

The objective of this guide is to make policymakers and regulators of energy efficient lighting programmes aware of the opportunities for using HS codes and more specifically, the additional national codes, for separating regulated lighting products and providing greater refinement of product types for monitoring the market transition to energy efficient lighting products.

Furthermore, this guide explains how the national codes provide an opportunity for member nations of economic trading blocks that have developed, or are developing, harmonized regulations for energy efficient appliances and lighting to establish agreed regionally harmonized national tariff and statistical codes. This collaborative approach facilitates a better assessment of the import and export flow of the target products between countries, as well as adding a robust verifiable source to monitoring, verification and reporting activities for regulatory programmes on energy efficient lighting and appliances.

## 3 INTRODUCTION TO THE HARMONIZED SYSTEM CODE

### 3.1 History

Throughout history customs duties have been levied on transportable merchandise traded between countries and empires. While tariffs were being levied at a single rate across all products, identification of the merchandise was not required, but once tariffs were varied dependent on the merchandise type, identification was necessary and ultimately a grouping of similar goods was needed. Initially implemented as an alphabetical tabulation of merchandise with the tariff to be applied, over time countries progressed to a categorisation (or nomenclature) based on systematic classification of goods. An example of an early nomenclature would be grouping by the nature of the merchandise (e.g., live animals, flours, stone, earth and other minerals etc.).

When differing nomenclatures are used by trading countries it is difficult to analyse trade statistics for individual commodities, as each importing or exporting country may assign a commodity to unique categories containing a different mix of other goods. As an example, if multiple countries used three different nomenclatures for vehicles as described in Table 1, there is no possibility of determining the statistics for trade flowing between individual countries for specific commodities. As a specific example, a domestic vehicle exported from Country A could be imported into (i) Country B as any of the engine/motor types or (ii) Country C as any vehicle type.

*Table 1: An example of non-harmonized commodity categories for vehicles*

Nomenclature for Vehicles in Country A	Nomenclature for Vehicles in Country B	Nomenclature for Vehicles in Country C
<b>Domestic vehicle</b>	Vehicle with diesel engine	Car
<b>Commercial vehicle</b>	Vehicle with petrol engine	Truck
<b>Agricultural vehicle</b>	Vehicle with LPG engine	Bus
	Vehicle with electric motor	Tractor
		Motor bike
		Scooter

The twentieth century delivered increasing international cooperation in trade, identifying a need for the simplification and unification of tariff nomenclatures as essential to improve revenue collection and facilitate trade. After multiple iterations, influenced by country-based nomenclatures, a set of four-digit headings for international use entered into force in 1959.

By 1970, the limited granularity in the four-digit headings for the world's economies, which made it difficult to use them as the sole basis for their customs tariffs or for the collection of trade statistics, instigated the development of the six-digit Harmonized Commodity Description and Coding System, generally referred to as Harmonized System or simply the HS.

The Harmonized System came into force on 1<sup>st</sup> January 1988 and is administered and maintained by the World Customs Organization. As of October 2020, 211 countries and economic unions (represented by 158 contracting parties) were applying the Harmonized System via 184 Customs administrations which collectively process approximately 98% of world trade.

## 3.2 Structure

The Harmonized System is based on a core internationally recognised six-digit code for commodities (the HS code) and includes provision for the addition of a four-digit national component with nation-centric codes unique to each country's regulatory and statistical needs. The resulting 10-digit commodity code used by most Customs administrations is shown in Figure 1. International HS codes are revised every five years to maintain their relevance to product development and consumer habits. This process is further detailed in Section 3.4.

Figure 1: 10-digit commodity code structure

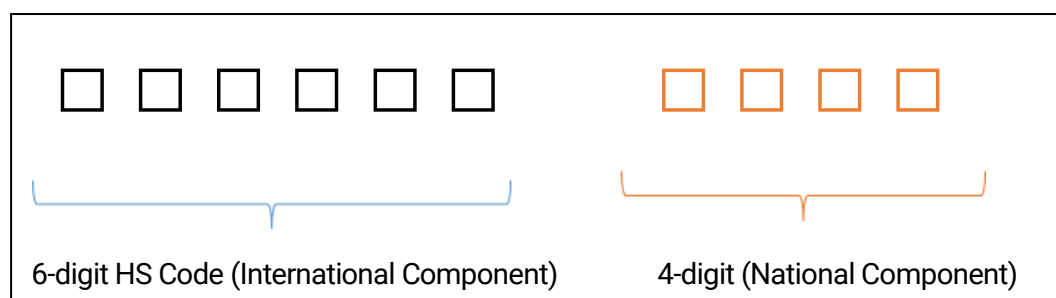

Data from the international and national codes can be used by Customs administrations, statisticians, government regulators, logistics and merchant agents. The Harmonized System's capacity to uniquely identify product categories provides a robust legal and logical structure for commodity trade.

## 3.3 HS Code

The six-digit Harmonized System has 21 Sections describing the main categories of commodities as listed in Table 2. The Section numbers are not part of the 6-digit HS code but provide a simplified reference to the titles of the commodity categories.

The 21 Sections are separated into a combined total of 97 Chapters. As a general rule, goods are arranged (starting from Chapter 01) in order of their degree of manufacture: from animals, plants and raw materials, through unworked products, semi-finished products to finished products. The Chapter numbers contained within each Section are provided in Table 2. Lighting products are finished products, so they are deep into the chapter coding sequence (namely in Section XVI, Chapter 85 and Section XX, Chapter 95). A full description of all the Chapters is provided in Annex A: Chapter numbers and descriptions within Sections of HS2022.

*Table 2: Listing of Section numbers for referencing commodity category titles and the Chapter numbers within each Section*

<b>Section No</b>	<b>Chapters</b>	<b>Commodity Category Title</b>
I	1 – 5	Live animals; animal products
II	6 – 14	Vegetable products
III	15	Animal, vegetable or microbial fats and oils and their cleavage products; prepared edible fats; animal or vegetable waxes
IV	16 – 24	Prepared foodstuffs; beverages, spirits and vinegar; tobacco and manufactured tobacco substitutes; products, whether or not containing nicotine, intended for inhalation without combustion; other nicotine containing products intended for the intake of nicotine into the human body
V	25 – 27	Mineral products
VI	28 – 38	Products of the chemical or allied industries
VII	39 – 40	Plastics and articles thereof; rubber and articles thereof
VIII	41 – 43	Raw hides and skins, leather, furskins and articles thereof; saddlery and harness; travel goods, handbags and similar containers; articles of animal gut (other than silk-worm gut)
IX	44 – 46	Wood and articles of wood; wood charcoal; cork and articles of cork; manufactures of straw, of esparto or of other plaiting materials; basketware and wickerwork
X	47 – 49	Pulp of wood or of other fibrous cellulosic material; recovered (waste and scrap) paper or paperboard; paper and paperboard and articles thereof
XI	50 – 63	Textiles and textile articles
XII	64 – 67	Footwear, headgear, umbrellas, sun umbrellas, walking-sticks, seat-sticks, whips, riding-crops and parts thereof; prepared feathers and articles made therewith; artificial flowers; articles of human hair
XIII	68 – 70	Articles of stone, plaster, cement, asbestos, mica or similar materials; ceramic products; glass and glassware
XIV	71	Natural or cultured pearls, precious or semi-precious stones, precious metals, metals clad with precious metal, and articles thereof; imitation jewellery; coin
XV	72 – 83	Base metals and articles of base metal
XVI	84 – 85	Machinery and mechanical appliances; electrical equipment; parts thereof; sound recorders and reproducers, television image and sound recorders and reproducers, and parts and accessories of such articles
XVII	86 – 89	Vehicles, aircraft, vessels and associated transport equipment
XVIII	90 – 92	Optical, photographic, cinematographic, measuring, checking, precision, medical or surgical instruments and apparatus; clocks and watches; musical instruments; parts and accessories thereof
XIX	93	Arms and ammunition; parts and accessories thereof
XX	94 – 96	Miscellaneous manufactured articles
XXI	97	Works of art, collectors' pieces and antiques

Chapters are denoted by the first two digits in the HS code (and represented by “AA” in Figure 2). The Chapters are further separated into Headings (the two-digit pair represented by “BB” in Figure 2) with final separation into Subheadings (the two-digit pair represented by “C<sub>1</sub>C<sub>2</sub>” in Figure 2). The concatenation of these three pairs of two-digits constitutes the six-digit HS code, Figure 2, which forms the internationally harmonized component of the Harmonized System code structure.

Figure 2: Identification of the three groups of paired digits of the international component which makes up the six-digit HS code

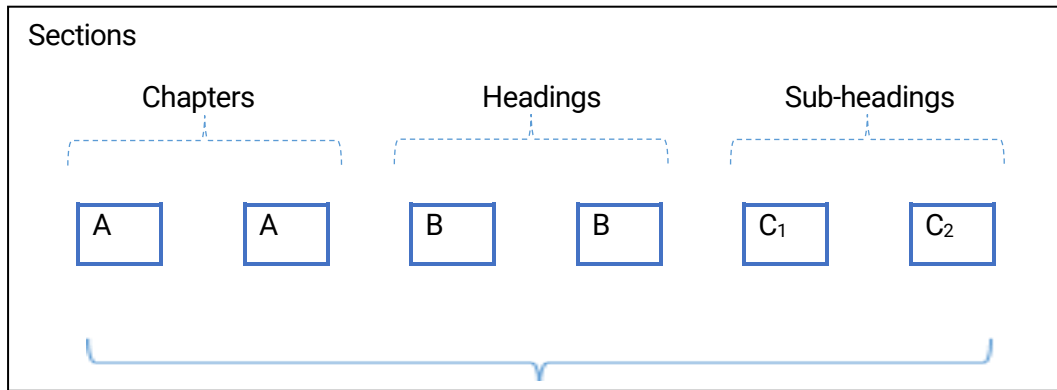

As an example, Section I (Live Animals; Animal Products) has five Chapters describing different subset groups of live animals or animal products, as shown in Table 3. The associated Chapter number provides the “AA” (Figure 2) for the six-digit HS Code for the described subset group.

Table 3: The separation of Section I (Live Animals; Animal Products) into Chapters

	Six-digit HS Code					
	A	A	B	B	C <sub>1</sub>	C <sub>2</sub>
Section 1: Live Animals; Animal Products						
Chapter 01: Live Animals	0	1				
Chapter 02: Meat and edible meat offal	0	2				
Chapter 03: Fish and crustaceans, molluscs and other aquatic invertebrates	0	3				
Chapter 04: Dairy produce; birds' eggs; natural honey; edible products of animal origin, not elsewhere specified or included	0	4				
Chapter 05: Products of animal origin, not elsewhere specified or included	0	5				

Note that Chapter 05, being the last Chapter within Section I, is designed as a “catch-all” for remaining Live Animal and Animal Products not covered by the preceding Chapters (01 – 04) within the Section. This principal is applied to the last Chapter within all Sections.

Headings provide subdivision within a Chapter. The Heading numbers enumerate a sequential order of the commodity groups within a Chapter. Using Chapter 01 (Live Animals) as an example, the Headings in Table 4 apply.



Table 4: The separation of Chapter 01 (Live Animals) into Headings

		Six-digit HS Code					
		A	A	B	B	C <sub>1</sub>	C <sub>2</sub>
Section 1: Live Animals; Animal Products							
Chapter 01: Live Animals							
Heading 01:	Live horses, asses, mules and hinnies.	0	1				
Heading 02:	Live bovine animals.	0	1	0	1		
Heading 03:	Live swine.	0	1	0	2		
Heading 04:	Live sheep and goats.	0	1	0	3		
Heading 06:	Other live animals.	0	1	0	4		
		0	1	0	6		

Note again that Heading 06, being the last Heading within Chapter 01, is designed as a “catch-all” for remaining Live Animals not covered by the preceding Headings (01 – 05) within the Section. This principal is applied to the last Heading within all Chapters.

If a commodity has no further subdivision beyond the Heading, the Subheading is designated as 00.

If further subdivision is required then, unlike Headings which are purely sequential numbering within the Chapter, Subheadings provide a two-tiered subdivision of the commodities within the Heading. The first tier of subdivision is designated by the first digit, C<sub>1</sub> in Figure 2 and the second tier of subdivision, when required, is designated by the second digit, C<sub>2</sub> in Figure 2. There are only nine (1 through to 9) subdivisions available for both Subheading tiers. If a commodity only requires one tier of subdivision, then the second digit of the Subheading (C<sub>2</sub> in Figure 2) is 0.

Continuing with the example above but now subdividing Heading 01 (Live horses, asses, mules and hinnies) the Subheadings in Table 5 apply.

Table 5: The separation of Heading 0101 (Live horses, asses, mules and hinnies) into Subheadings

		Six-digit HS Code					
		A	A	B	B	C <sub>1</sub>	C <sub>2</sub>
Section 1: Live Animals; Animal Products							
Chapter 01: Live Animals							
Heading 01:	Live horses, asses, mules and hinnies.	0	1				
Subheading 2: - Horses:		0	1	0	1		
↳Subheading 21: – Pure-bred breeding animals		0	1	0	1	2	1
↳Subheading 29: – Other		0	1	0	1	2	9
Subheading 30: - Asses		0	1	0	1	3	0
Subheading 90: - Other		0	1	0	1	9	0

Important points to note in relation to Subheadings:

- The enumeration of the Subheadings does not need to be a continuous unbroken sequence of numbers. Strategic allocation of numbering allows for future subdivisions which may be best assigned between the existing subdivision groups. In this example, first tier Subheadings, 1 and 4 through to 8 are available for future use.
- The first tier Subheading 2: Horses is divided into two second tier groups, 21: pure-bred breeding animals and 29: Other (capturing all other horses). The use of the number 29 facilitates the possibility for the creation of future subdivision groups (i.e., 22 to 28) under horses, if and when required.
  - The Subheading number 20 cannot be used in this situation due to there being subdivisions at the second tier. This means that “010120: Horses” is NOT a valid HS code.
- No further subdivision of first tier Subheading group 3: Asses is currently required so the second-tier digit is assigned 0, creating Subheading 30.
- To facilitate inclusion of future additional subheadings, Subheading 90: Other is assigned as the last Subheading within the Heading 01: Live horses, asses, mules and hinnies, to be the “catch-all” for remaining commodities not covered by the preceding Subheadings (21 – 30) within the Heading. This principal is applied to the last Subheading within all Headings.

Therefore, the combined six-digit code comprised of the two-digit codes representing the Chapter, Heading and Subheading is required to provide the unique identification of a commodity group. There are over 5,000 commodity groups.

A full detailed online listing of all HS codes is provided on the World Customs Organization website<sup>2</sup>. Note that most of the detailed services provided on this WCO TradeTools website are subscription based.

Individual pdf documents listing all six-digit commodity groups collated at the four-digit (Chapter/Heading) level are available for free download<sup>3</sup>. Notes are provided at the beginning of each Section and Chapter to clarify which commodities are covered within, as well as meanings of terms that warrant clarification.

### 3.4 Maintenance and updates of international HS codes

To maintain the relevance of the Harmonized System, it is revised on a five-year cycle. This ensures that technology evolution and consumer habits are taken into account. Only Contracting Parties to the Harmonized System can take part in the administration and maintenance processes, including proposing amendments. A full list of Contracting Parties to the Harmonized System Convention, (including their status in relation to implementation of the latest version of the Harmonized System) and Non-Contracting Parties which apply the HS Convention is available for download from the World Customs Organization website.<sup>4</sup>

The 2022 version is the most recent revision of the Harmonized System and incorporates 351 amendments to the previous 2017 version.

---

<sup>2</sup> <https://www.wcotradetools.org/en/harmonized-system>.

<sup>3</sup> <http://www.wcoomd.org/en/topics/nomenclature/instrument-and-tools/hs-nomenclature-2022-edition/hs-nomenclature-2022-edition.aspx>

<sup>4</sup> [https://www.wcoomd.org/-/media/wco/public/global/pdf/topics/nomenclature/overview/hs-contracting-parties/positions-of-cp/situation\\_hs.pdf?db=web](https://www.wcoomd.org/-/media/wco/public/global/pdf/topics/nomenclature/overview/hs-contracting-parties/positions-of-cp/situation_hs.pdf?db=web)

Changes to the nomenclature can involve:

- Changes to the explanatory notes.
- Adding new classification codes.
- Replacing an existing classification code with multiple classification codes to provide greater granularity.
- Deleting of classification codes with low trade volumes.

Examples of such revision types in the lighting sector are:

- In the 2017 version, the HS-code 853950 “*Light-emitting diode (LED) lamps*” was first added. Previously there was no specific HS code for LED lighting products.
- Then in the 2022 version, this classification was replaced so it could be subdivided into two separate classification codes for LED lamps and modules. This was achieved by:
  - Deleting HS code 853950: “*Light-emitting diode (LED) lamps*”,
  - Creating a first tier Subheading 85395: “*Light-emitting diode (LED) light sources*”,
  - And adding HS codes for second tier Subheadings,
    - 853951: “*Light-emitting diode (LED) modules*”,
    - 853952: “*Light-emitting diode (LED) lamps*”.

During the course of a five-year period, if further amendments are deemed necessary “complementary amendments” or “corrigendum amendments” may be issued<sup>5</sup>.

### 3.5 National component

The national component of the 10-digit commodity code is theoretically unique to an individual country and developed for their specific needs. The national component incorporates a tariff code and a statistical code and has four digits that are concatenated, as shown in Figure 3, and appended to the end of the six-digit (international) HS code. That means a country can obtain additional granularity beyond the internationally harmonized six-digit HS code commodity group by subdividing into smaller more specific groups. The administration of a country’s national component is normally managed by the Ministry of Finance.

Figure 3: Identification of the two groups of paired digits of the four-digit national component

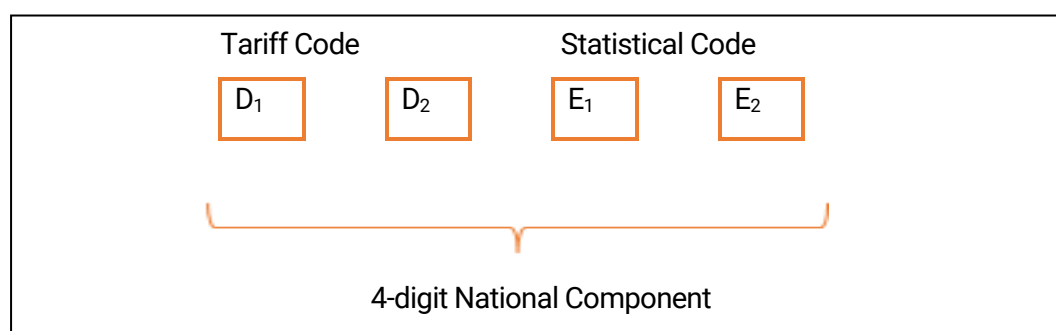

<sup>5</sup> For the 2022 version these can be found on the at: <http://www.wcoomd.org/en/topics/nomenclature/instrument-and-tools/hs-nomenclature-2022-edition.aspx>.

### 3.6 Use of tariff and statistical codes as part of energy efficient product strategy

As part of the implementation strategy of their market transformation to energy efficient lighting, some countries use import tariffs as a financial mechanism for promoting energy efficient products over inefficient product forms of the same commodity. For example, Pakistan has a different customs duty for a HS code: 853931 “hot cathode fluorescent discharge lamp” based on whether it is an “energy saving lamp” (tariff code of 10 with a customs duty = 3%), an “energy saving tube” (tariff code of 20 with a customs duty = 3%) or any “other” (tariff code of 90 with a customs duty = 20%). The customs duties are applied irrespective of the statistical codes assigned to any of these products as statistical codes are a further subdivision below the tariff code assignment.

Combined, the tariff and statistical codes provide for a four-tiered subdivision for those commodities having the same six-digit (international) HS code thereby allowing for greater refinement of commodity groups.

The national component of a commodity code provides an opportunity for member nations of economic trading blocks that have developed, or are developing, harmonized regulations for energy efficient appliances and lighting to establish agreed regionally harmonized national tariff and statistical codes. This collaborative approach facilitates a better assessment of the import and export flow of the target products between countries as well as adding a robust, verifiable source to monitoring, verification and reporting activities for regulatory programs on energy efficient lighting and appliances.

#### Tariff Codes

The first two digits in Figure 3 are allocated for tariff codes. These are used when a country wants to have different levels of import duty (tax) for different commodities within a single six-digit HS code. As an example, a country may wish to impose different tariffs on commodities within HS code 853910: “sealed beam lamp units” such that those for motorcycles are free of import duty, while all remaining lamps under 853910 are subject to a 5% tariff. This commodity segregation could be achieved by creating the tariff codes shown in Table 6.

Table 6: Example of tariff codes used to differentiate import duty levels

	Four-digit National Code				Tariff
	D <sub>1</sub>	D <sub>2</sub>	E <sub>1</sub>	E <sub>2</sub>	
853910: Sealed beam lamp units					
Tariff 10: For motorcycles	1	0			Free
Tariff 90: Other	9	0			5%

If the tariff is the same for all commodities within a six-digit HS code, then the tariff code will be 00.

## Statistical Codes

The last two digits in Figure 3 are allocated for statistical codes. They provide another mechanism for further subdivisions of commodities beyond the six-digit HS code classification for obtaining information on international trade statistics. Statistical codes are typically created and used by relevant government agencies for the purposes of monitoring and reporting in relation to government policies and regulations.

As an example, a country may wish to monitor the market transition of different lengths of linear fluorescent tubes to linear LED tubes, expecting that the market may transition more quickly for the most commonly installed lengths (550 – 1200 mm, 2 – 4 ft). This commodity segregation could be achieved by creating the tariff codes such as those in Table 7.

Table 7: Example of statistical codes used to differentiate commodities

		Four-digit National Code			
		D <sub>1</sub>	D <sub>2</sub>	E <sub>1</sub>	E <sub>2</sub>
85393: Discharge lamps, other than ultra-violet lamps:					
853931: – Fluorescent, hot cathode					
Statistic 1: straight type					
↳Statistic 11: No more than 550 mm in length					
↳Statistic 12: Between 550 and 1200 mm in length					
↳Statistic 13: Greater than 1200 mm in length					
↳Statistic 90: Other lamps					
				1	
				1	1
				1	2
				1	3
				9	0

If differing tariffs are also applied by a different classification criterion amongst all the commodities with the same six-digit HS code, then they are applied first, and the statistical codes are assigned second. An example could be where halo-phosphor tubes (older, less efficient technology) have a higher tariff than multi-phosphor tubes, but statistical information is still desired in relation to imports by tube length. This commodity segregation could be achieved by creating the tariff and statistical codes such as those in Table 6.

Similar commodity segregations at statistical code level to Table 7 and Table 6 would also be required for linear LED tubes within 853952: “LED lamps” to allow like-for-like comparison (with linear fluorescent lamps) of the import statistics.

Table 8: Example of combination of tariff and statistical codes used to differentiate commodities and tariffs

	Four-digit National Code				Tariff
	D <sub>1</sub>	D <sub>2</sub>	E <sub>1</sub>	E <sub>2</sub>	
85393: Discharge lamps, other than ultra-violet lamps:					
853931: – Fluorescent, hot cathode					
Tariff 10: halo-phosphor	1	0			20%
Statistic 1: straight type	1	0	1		
↳ Statistic 11: No more than 550 mm in length	1	0	1	1	
↳ Statistic 12: Between 550 and 1200 mm in length	1	0	1	2	
↳ Statistic 13: Greater than 1200 mm in length	1	0	1	3	
↳ Statistic 90: Other lamps	1	0	9	0	
Tariff 90: other	9	0			5%
Statistic 1: straight type	9	0	1		
↳ Statistic 11: No more than 550 mm in length	9	0	1	1	
↳ Statistic 12: Between 550 and 1200 mm in length	9	0	1	2	
↳ Statistic 13: Greater than 1200 mm in length	9	0	1	3	
↳ Statistic 90: Other lamps	9	0	9	0	

## 4 COMMODITY CLASSIFICATION

To correctly classify a commodity within the Harmonized System it is important to have:

- Detailed knowledge of the commodity to be classified.
- A good understanding of the meaning of the classification terms.
- The diligence to follow a rigid classification process.

### 4.1 Detailed knowledge of the commodity

The full classification of a commodity relies upon multiple criteria which may relate to an array of features possessed by the commodity. Examples of possible assigned features include: physical dimensions, chemical composition, construction material, power consumption, technology type, and purpose or application of the commodity. So, obtaining all such information about a commodity prior to undertaking its classification in the Harmonized System is necessary. This is especially the case when classifying to the full (international and national) 10-digit code, where criteria for numerous features may be required.

Some examples of features that are required to be known to classify certain commodities are:

<b>Commodity</b>	<b>Classification features</b>
Lamps:	<ul style="list-style-type: none"> <li>• Light source technology</li> <li>• Physical dimensions</li> <li>• Lamp cap type</li> <li>• Power consumption</li> <li>• Light distribution</li> </ul>
Batteries:	<ul style="list-style-type: none"> <li>• Chemical composition</li> </ul>
Domestic washing machines	<ul style="list-style-type: none"> <li>• Automation level</li> <li>• Load capacity</li> </ul>
Refrigerators, freezers	<ul style="list-style-type: none"> <li>• Door configuration</li> <li>• Cooling technology</li> <li>• Capacity (volume)</li> <li>• Display of contents</li> </ul>

### 4.2 The meaning of classification terms

Classification terms are generally self-explanatory without the need for explicitly defining the meaning of each term. Where definitions are deemed necessary to describe the intended purpose of the commodity, they are published as part of the “notes” at the beginning of the relevant Sections and Chapters. It is important to understand that these definitions may not be exactly the same as those defined by other organisations/entities (e.g., standards bodies, regulators etc). The “notes” for the relevant Chapter therefore should be reviewed for the applicable meanings of terms prior to classifying a commodity in order to faithfully assign the correct HS code.

An example of such a definition, shown in Figure 4, is Note 11 at the beginning of Chapter 85 (HS2022) for “light-emitting diode (LED) light sources”.

Figure 4: Definition of LED light source, from HS2022

11.-For the purposes of heading 85.39, the expression “light-emitting diode (LED) light sources” covers :

- (a) “Light-emitting diode (LED) modules” which are electrical light sources based on light-emitting diodes (LED) arranged in electrical circuits and containing further elements like electrical, mechanical, thermal or optical elements. They also contain discrete active elements, discrete passive elements, or articles of heading 85.36 or 85.42 for the purposes of providing power supply or power control. Light-emitting diode (LED) modules do not have a cap designed to allow easy installation or replacement in a luminaire and ensure mechanical and electrical contact.
- (b) “Light-emitting diode (LED) lamps” which are electrical light sources containing one or more LED modules containing further elements like electrical, mechanical, thermal or optical elements. The distinction between light-emitting diode (LED) modules and light-emitting diode (LED) lamps is that lamps have a cap designed to allow easy installation or replacement in a luminaire and ensure mechanical and electrical contact.

### 4.3 Classification process

The classification procedure is a sequential set of steps where no reversal or back-tracking of direction through the system is permitted. This is illustrated in Figure 5 and described below for the international component (six-digit) HS code.

**Step 1:** Starting at Chapter 01 (Live Animals), movement is down through the 96 Chapters until of the commodity of interest is identified within the broad description (in Figure 5, the selected Chapter number is represented by “AA”).

**Step 2:** Commencing at the first Heading 01 in the selected Chapter (“AA”), work down through the Headings until a more refined description of the commodity is identified (in Figure 5, the selected Heading is represented by “BB”). This completes the first four digits “AABB”.

**Step 3:** Commencing at the first tier Subheading 1, work down through the first tier Subheadings until a more refined description of the commodity is identified (in Figure 5, the selected first-tier Subheading is represented by “C<sub>1</sub>”). This completes the first five digits “AABBC<sub>1</sub>”.

**Step 4:** Commencing at the second tier Subheading 0, work down through the second tier Subheadings until a further refined description of the commodity is identified (in Figure 5, the selected second-tier Subheading is represented by “C<sub>2</sub>”). The six-digit HS Code, “AABBC<sub>1</sub>C<sub>2</sub>”, has now been fully resolved for the commodity of interest.

Continuing this same process through Steps 5 to 8 in Figure 5 will then resolve the four-digit national component of the HS code, “D<sub>1</sub>D<sub>2</sub>E<sub>1</sub>E<sub>2</sub>” for the commodity. This code will be specific to the importing or exporting nation.



Figure 5: Procedural steps for HS code classification

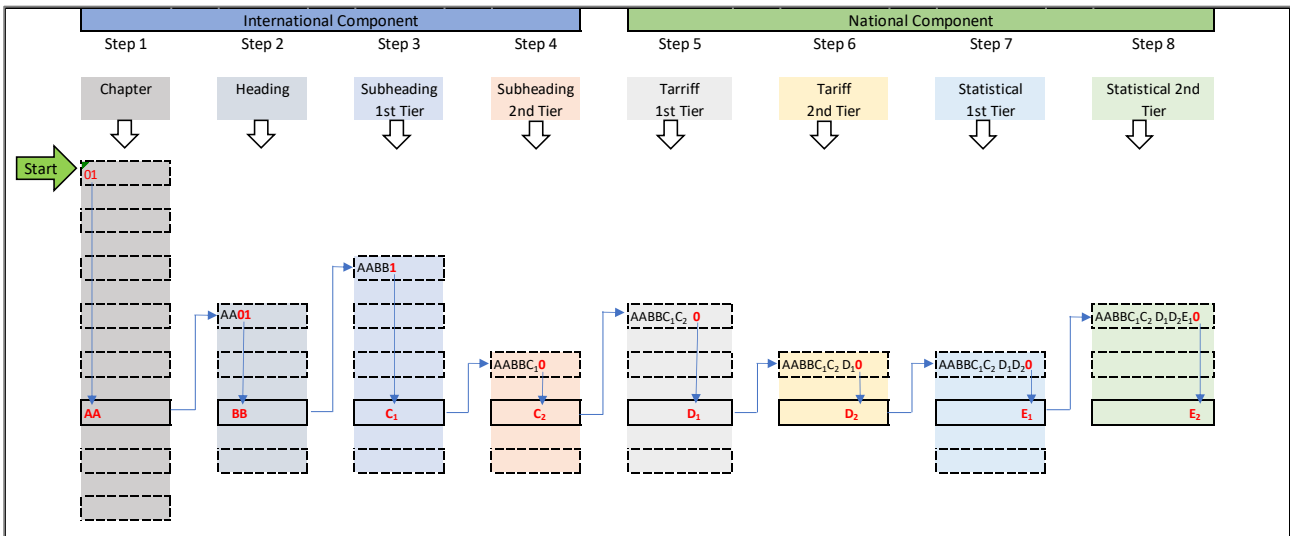

The following example, illustrated in Figure 6, demonstrates the process for determining the 10-digit commodity code for an LED lamp to be imported into Australia that has the following features: double capped linear LED tube, 1200 mm long, G13 caps. Details of the four-digit national component for Australia, necessary to complete Steps 5 to 8 can be found at a link listed on the WCO website with all other member countries<sup>6</sup>.

The procedure for determining the six-digit HS code (international component) is:

**Step 1:** Starting at Chapter 01 (Live Animals), move down through the Chapters assessing suitability until Chapter 85: “Electrical machinery and equipment and parts thereof; sound recorders and reproducers, television image and sound recorders and reproducers, and parts and accessories of such articles” is reached and it is identified that electric lighting products belong within electrical equipment.

**Step 2:** Starting at Heading 01 within Chapter 85 move down until Heading 39: “Electric filament or discharge lamps, including sealed beam lamp units and ultra-violet or infra-red lamps; arc-lamps; light-emitting diode (LED) light sources” is reached and it is identified that the LED tube belongs within light-emitting diode (LED) light sources.

**Step 3:** Starting at first-tier Subheading 1 within Heading 39 move down until first-tier Subheading 5: “Light-emitting Diode (LED) light sources” is reached and it is identified that the LED tube belongs within light-emitting diode (LED) light sources.

**Step 4:** Starting at second-tier Subheading 0 within first-tier Subheading 5 move down until second-tier Subheading 2: “Light-Emitting Diode (LED) lamps” is reached and it is identified that the LED tube belongs within light-emitting diode (LED) lamps.

The six-digit HS code, 853952, has now been fully resolved for the linear LED tube under investigation.

<sup>6</sup> <http://www.wcoomd.org/en/topics/nomenclature/resources/national-and-international-customs-tariff/national-tariff.aspx>

The procedure for determining the four-digit national component (for Australia) is:

**Steps 5 & 6:** Starting at first-tier Tariff 0 within second-tier Subheading 2 it is determined that there is no further segregation of light-emitting diode (LED) lamps for different custom duties in Australia so both tiers of the tariff are assigned 0. That is all LED lamps (853952) have the same tariff (and 8-digit code 853952 00).

**Step 7:** Starting at first-tier Statistical 0 within Tariff 00 move down until first-tier Statistical 4: "LED Linear lamp with G13 or G5 cap" is reached and identified as the correct classification.

**Step 8:** Starting at second-tier Statistical 0 within first-tier Statistical 4 move down until second-tier Statistical 3: "Greater than or equal to 1150 mm but less than 1350 mm in length" is reached and identified as the correct classification.

The four-digit national component has now been fully resolved, thereby completing the full 10-digit code, 853952 0043, for the linear LED tube under investigation.

Figure 6: Example of procedural steps for determining the HS code for a linear LED tube

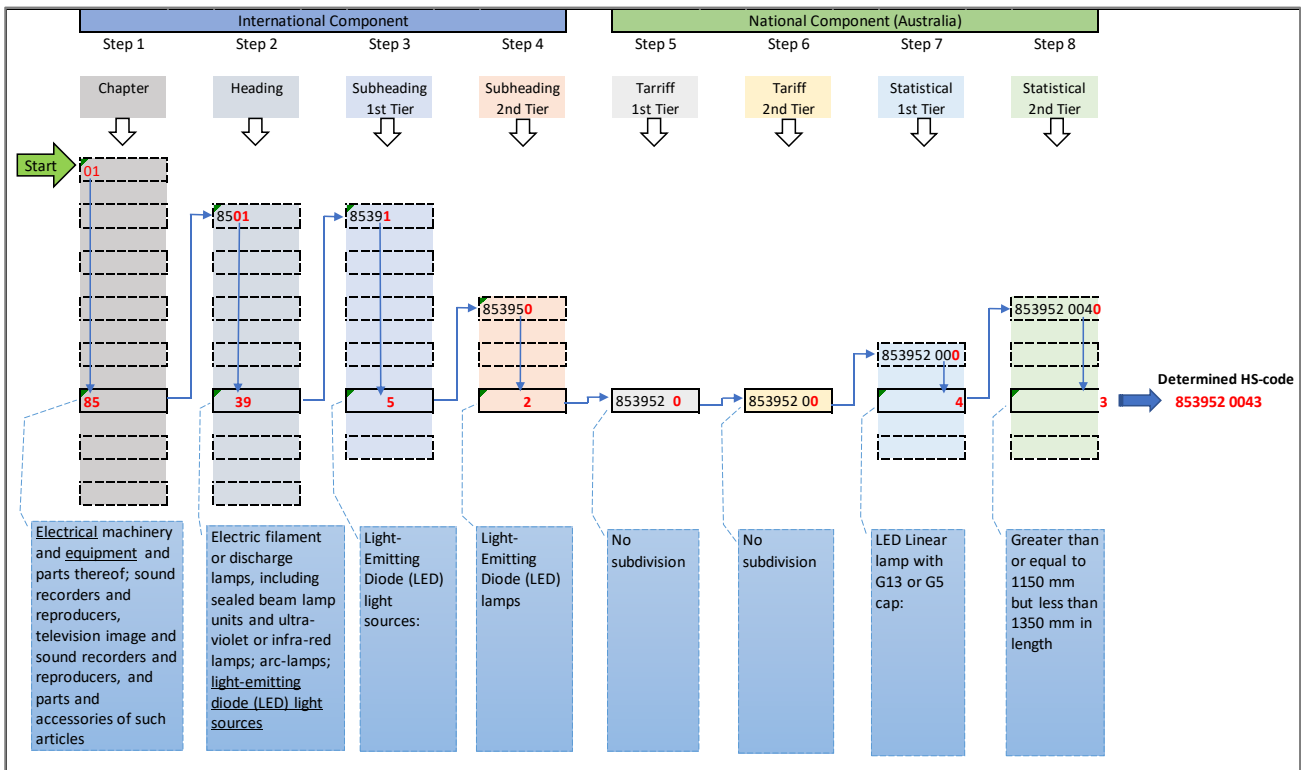

If the details of the national component (tariff and statistical codes) of a country are required, they can be sourced from the country's relevant government agency/department (e.g., Bureau of Statistics, Border Forces, Home Affairs) which may also be found at the following WCO website link<sup>7</sup>. The full classification of a product with a 10-digit commodity code is achieved by following a continuation of the stepwise commodity description refinement described above.

For each step explained above, the titles to the Sections and Chapters are for descriptive purposes only and provided for ease of reference. For legal purposes, a classification is determined according to the relevant Section Notes or Chapter Notes (as explained in 4.2 above), and the terms of the headings, and these may be further elaborated in the General Rules for the Interpretation of the Harmonized System, and the accompanying Explanatory Notes to those General Rules<sup>8</sup>.

---

<sup>7</sup> <http://www.wcoomd.org/en/topics/nomenclature/resources/national-and-international-customs-tariff/national-tariff.aspx>

<sup>8</sup> <https://www.wcotradetools.org/en/harmonized-system/rules>

## 5 HS CODES ASSOCIATED WITH LIGHTING PRODUCTS

### 5.1 Overview of amendments to HS codes for lighting

The Amendments<sup>9</sup> to the sixth edition of the Harmonized System (HS2017) were approved in June 2019 and came into effect on 1 January 2022 as the seventh edition (HS2022). Since June 2019, additional amendments, known as Complementary Amendments<sup>10</sup>, have also been approved in June 2020 and June 2021 which will come into effect from 1 January 2023 and 2024 respectively.

Significant changes have been made between HS2017 and HS2022 in relation to lighting commodities. Acknowledging that LED lighting products are dominating the market and will ultimately replace all other light source technologies, a refinement of light-emitting diode product categories has been implemented along with improved definitions which should facilitate more accurate reporting of commodity types and quantities in the future. Therefore, the main changes between both version on the lighting sector, are:

1. LED packages which contained a broader group of products in HS2017 (854140) has now been separated into a new second-tier Subheading (854141)
2. LED lamps (853950), first introduced as its own 6-digit HS code in HS2017, has now been replaced at the first-tier Subheading level with LED light sources (85395), followed by two second-tier Subheadings to distinguish between LED modules (853951) and LED lamps (853952).
3. Integrated LED luminaires have also been segregated from conventional luminaires with lamp sockets through added definitions under the Subheadings within Heading 9405 "*Luminaires and lighting fittings...*".

### 5.2 Importance to energy efficiency policy and regulation activities

This greater granularity of lighting product HS codes provides an effective tool for policymakers and regulators of energy efficient lighting programmes by enabling separate analysis of import statistics for LED based lighting products and alternative traditional non-LED based lighting products.

Policymakers are now able to obtain quality data on the overall rate of market transformation in different lighting sectors (i.e., domestic, commercial, public). For example, comparison of annual import statistics for tungsten filament lamps (853922), halogen lamps (853921), fluorescent lamps (853931), mercury or sodium vapour and metal halide lamps (853932) and LED lamps (853952) can be undertaken to ascertain the rate of transition to LED lamps. A similar analysis can also now be conducted on the market transformation of luminaires, based on the light source technology used within (i.e., integrated LED vs socket-based luminaires which are predominantly non-LED lamps).

Regulators, with the support of Customs officials, can monitor lighting products entering the country and identify potentially banned products for inspection prior to import approval. For example, many countries have banned the import of tungsten filament lamps (except for a small number of specialist products that

<sup>9</sup> <http://www.wcoomd.org/-/media/wco/public/global/pdf/topics/nomenclature/instruments-and-tools/hs-nomenclature-2022/ng0262b1.pdf?db=web>

<sup>10</sup> <http://www.wcoomd.org/en/topics/nomenclature/instrument-and-tools/hs-nomenclature-2022-edition/complementary-amendments-to-the-hs-nomenclature.aspx>

are exempt) as part of their Minimum Energy Performance Standards (MEPS). Since tungsten filament lamps have their own six-digit HS code (853922), import applications for commodities with this HS code will warrant additional scrutiny and inspection, to determine that they are indeed MEPS-exempt products.

Granularity of lighting product types can be increased by using a country's opportunity for creating national tariff and statistical codes. Tariff codes are typically utilised when a financial penalty, by way of a higher import duty, is placed on less-efficient product forms rather than using a MEPS regulation. Statistical codes are effective when wanting to separate products that are in-scope of a regulation from those that are outside the scope. One example of such a situation is where a MEPS is placed on non-directional LED lamps but not on directional LED lamps. Both product types have the same international six-digit HS code (853952) so creating national statistical codes for each (e.g., 10 for non-directional and 20 for directional) will facilitate more effective policy and compliance investigations.

Further explanation on the use of HS code import data for trend analysis, border control and MVR and MVE activities is discussed in Section 6 of this document.

### 5.3 Managing changes to HS codes for lighting products in HS2022

All lighting products are classified within two Chapters:

- Section XVI, Chapter 85: "Electrical machinery and equipment and parts thereof; sound recorders and reproducers, television image and sound recorders and reproducers, and parts and accessories of such articles" contains Headings which include lighting control gear (8504), lamps (8539) and lighting electronic components (8541).
- Section XX, Chapter 94: "Furniture; bedding, mattresses, mattress supports, cushions and similar stuffed furnishings; luminaires and lighting fittings, not elsewhere specified or included; illuminated signs, illuminated name-plates and the like; prefabricated buildings" contains a single Heading (9405) which includes forms of luminaires. Subheadings within all these stated Headings provide various levels of classification granularity to lighting-related commodities, the details of which are set out in Table 9 and Table 10.

As mentioned in Section 5.1, the changes to HS code classifications from HS2017 to HS2022 need to be understood for two reasons.

Firstly, countries may require time beyond the WCO designated entry-into-force date to convert their systems to the updated HS2022 codes. During this time, importers are required to continue using the HS2017 classification codes for importing products to that country. This means, for example that LED lamps may continue in 2022 to be classified as 853950 (from HS2017) rather than 853952 (from HS2022).

Secondly, policy and regulatory programme activities need to be cognisant of the amendments that affect commodities relevant to the programmes. This is generally due to greater granularity being introduced for a product's classification. For example, as illustrated in Figure 7, the HS code for LED lamps has changed from HS2017 (LED lamps: 853950) to HS2022 (LED lamps: 853952), and any investigation of import trends will require linking of data from both HS codes for the analysis.

Figure 7: Example of linking LED lamp import statistics when HS codes change

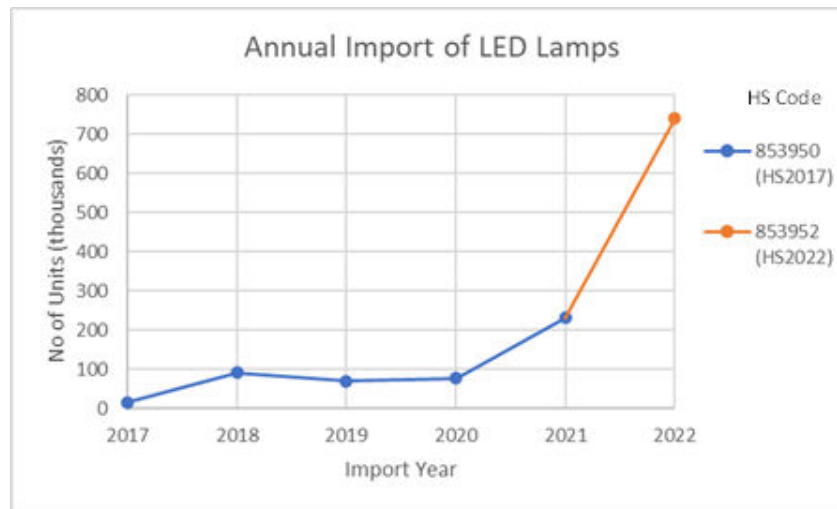

Another example is found for general indoor luminaires, which up until HS2017 were classified by first-tier Subheading 940510: “Chandeliers and other electric ceiling or wall lighting fittings, excluding those of a kind used for lighting public open spaces or thoroughfares”. However, amendments in HS2022 have segregated this group into two second-tier Subheadings: integrated LED luminaires (940511: “Designed for use solely with light-emitting diode (LED) light sources”) and conventional lamp-based luminaires (940512: “Other”). This provides greater granularity of the import data moving forward but does not provide any historical information prior to the HS2022 code amendments, as illustrated in Figure 8. Note that in this figure, for 2022, the total indoor luminaires series is the sum of the products in Subheadings 940511 and 940512, and is denoted using the five-digit, first-tier Subheading 94051. In situations like this, where detail is discontinuous or absent, policymakers may use other data sources, such as industry sales data or estimated proportions of installed luminaire types, to construct possible import trends prior to the amended HS codes.

Figure 8: Example of indoor luminaire import statistics becoming segregated with HS code changes

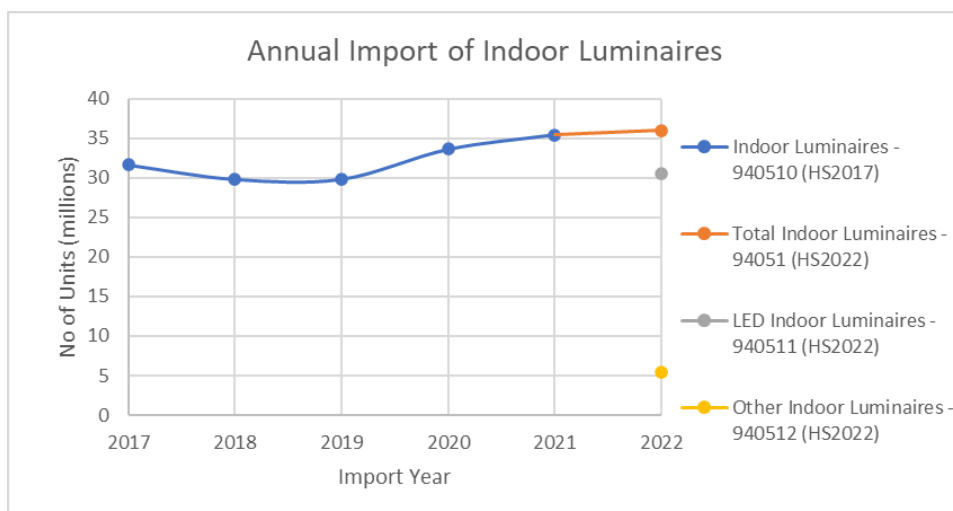

From these illustrated examples, it is evidently important that policymakers and regulators of energy efficient lighting programmes understand the correlation of commodity classification amendments between HS2017 and HS2022.

To assist with an understanding of the changes, Table 9 and Table 10 have been constructed with colour-coded text to provide a clear reading of the pertinent information that has changed. Specifically:

- **Red text** highlights (for ease of locating) the descriptor text and six-digit codes from HS2017 under which lighting products are classified,
  - Descriptor text and six-digit codes with ~~strikethrough~~ has been deleted from HS2022.
- **Blue text** highlights new HS codes and descriptors added in HS2022.

Note that some Headings (viz. 85.04 & 85.41) have many other commodity entries at Subheading level which have not been listed in these tables as they are not related to lighting products and as such are not relevant to this guide. To see the full listing refer to Annex B: HS2022 classifications for relevant lighting products.

From the tables it is apparent that, in HS2022:

1. LED drivers continue to be grouped in with all forms of static converters (8504.40).
2. Lamps continue to be segregated, predominantly based on light source technology, at the Subheading level (8539.xx).
3. LED modules (853951) have been included under the same Subheading as LED lamps (853952, replacing 853950 from HS2017) by creating a first-tier Subheading for LED light sources (85395).
4. A second-tier Subheading has been created to separate LED packages (854141) from the HS2017 first-tier Subheading (854140) which contained a broader group of products.
5. All first-tier Subheadings classifying luminaires and light fittings under Heading 9405, have second-tier Subheadings, which for the first-time segregate "*Designed for use solely with light-emitting diode (LED) light sources*". These are luminaires with integrated LED modules which cannot be fitted with non-LED lamps as opposed to all other lamp-based luminaires. As examples:
  - a. Indoor integrated LED luminaires are categorised as 940511
  - b. Outdoor integrated LED luminaires are categorised as 94054

Table 9: HS codes for lighting products in Section XVI

SECTION XVI	Machinery and Mechanical Appliances; <b>Electrical Equipment; Parts Thereof</b> ; Sound Recorders and Reproducers, Television Image and Sound Recorders and Reproducers, and Parts and Accessories of such Articles
Chapter 85	<b>Electrical machinery and equipment and parts thereof</b> ; sound recorders and reproducers, television image and sound recorders and reproducers, and parts and accessories of such articles
85.04	Electrical Transformers, <b>Static Converters</b> (For Example, Rectifiers) <b>and Inductors</b>
8504.10	- Ballasts for discharge lamps or tubes
8504.40	- Static converters
85.39	<b>Electric filament or discharge lamps</b> , including sealed beam lamp units and ultra-violet or infra-red lamps; arc-lamps; <b>light-emitting diode (LED) light sources</b> .
8539.2	- Other filament lamps, excluding ultra-violet or infra-red lamps:
8539.21	-- Tungsten halogen
8539.22	-- Other, of a power not exceeding 200 W and for a voltage exceeding 100V
8539.29	-- Other
8539.3	- Discharge lamps, other than ultra-violet lamps:
8539.31	-- Fluorescent, hot cathode
8539.32	-- Mercury or sodium vapour lamps; metal halide lamps
8539.39	-- Other
8539.50	- Light-emitting diode (LED) lamps
8539.5	- Light-emitting diode (LED) light sources
8539.51	-- Light-emitting diode (LED) modules
8539.52	-- Light-emitting diode (LED) lamps
8539.90	- Parts
85.41	Diodes, transistors and similar semiconductor devices; photosensitive semiconductor devices, including photovoltaic cells whether or not assembled in modules or made up into panels; <b>light-emitting diodes (LED)</b> , <b>whether or not assembled with other light-emitting diodes (LED)</b> ; mounted piezo-electric crystals.
8541.40	- Photosensitive semiconductor devices, including photovoltaic cells whether or not assembled in modules or made up into panels; <b>light-emitting diodes (LED)</b>
8541.4	
8541.41	-- Light-emitting diodes (LED)



Table 10: HS codes for lighting products in Section XX

SECTION XX	Miscellaneous manufactured articles
Chapter 94	Furniture; bedding, mattresses, mattress supports, cushions and similar stuffed furnishings; <del>lamps</del> luminaires and lighting fittings, not elsewhere specified or included; illuminated signs, illuminated name-plates and the like; prefabricated buildings
94.05	<del>Lamps</del> Luminaires and lighting fittings including searchlights and spotlights and parts thereof, not elsewhere specified or included; illuminated signs, illuminated name-plates and the like, having a permanently fixed light source, and parts thereof not elsewhere specified or included.
9405.10 9405.1	- Chandeliers and other electric ceiling or wall lighting fittings, excluding those of a kind used for lighting public open spaces or thoroughfares:
9405.11	- Designed for use solely with light-emitting diode (LED) light sources
9405.19	- Other
9405.2	- Electric table, desk, bedside or floor-standing luminaires:
9405.21	- Designed for use solely with light-emitting diode (LED) light sources
9405.29	- Other
9405.3	- Lighting strings of a kind used for Christmas trees:
9405.31	- Designed for use solely with light-emitting diode (LED) light sources
9405.39	- Other
9405.40 9405.4	- Other electric <del>lamps</del> luminaires and lighting fittings
9405.41	- Photovoltaic, designed for use solely with light-emitting diode (LED) light sources
9405.42	- Other, designed for use solely with light-emitting diode (LED) light sources
9405.49	- Other
9405.50	- Non-electrical luminaires and fittings
9405.6	- Illuminated signs, illuminated name-plates and the like:
9405.61	- Designed for use solely with light-emitting diode (LED) light sources
9405.69	- Other

## 5.4 National tariff codes for lighting products

As previously discussed, tariff codes are used when a country wants to have different levels of import duty (tax) for different commodities within a single six-digit HS code.

The two-digit tariff codes (as explained in Section 3.6) further refine the commodity groupings beyond the six-digit HS codes. This provides product segregation, which allows for the creation of differential custom duties that are used as drivers for various policies (e.g., energy efficiency, greenhouse gas reduction, mercury reduction, industry stimulus). These tariff codes may also provide the opportunity to monitor import trends and other quantities (e.g., estimated total mass of mercury imported in lamps) related to these tariff-defined groups and support monitoring, reporting and data verification of government programmes (e.g., energy efficient lighting and mercury reduction).

Countries will most likely already have established multiple tariffs within some of the six-digit HS code lighting product classifications. Pakistan for example, has lower custom duties for energy efficient lamps and associated parts within certain six-digit HS codes as part of its energy efficient lighting policy. Where energy efficient and inefficient products are classified within the same six-digit HS code, separate tariff codes have been created. Table 11 (lamps) provides a listing of tariff codes and associated custom duties in Pakistan for all commodities under the HS code Heading 8539: *“Electric filament or discharge lamps, including sealed beam lamp units and ultra-violet or infra-red lamps; arc-lamps; light-emitting diode (LED) light sources”* for 2021-2022. Those highlighted in green are where a lower custom duty of 3% is set for energy efficient products.

Review of existing tariff codes must be undertaken before a country considers using differential customs duties as a strategy for implementing energy efficient lighting policy. This is to ensure that any product within the six-digit HS code has a unique tariff code that applies to its description, otherwise where multiple codes are applicable importers will obviously report the tariff code with the lowest custom duty. When a country has no existing tariff codes or wishes to review all such codes for a product group such as lamps (Heading: 8539), consideration could be given to defining tariff classifications that align with the scope of products included in any existing or intended MEPS and labelling regulations – thereby providing an additional financial duty on the poorer performing products.

When differential custom duties are not part of the strategy for implementation of an energy efficient lighting programme, the one remaining commodity code mechanism available to policymakers and regulators for monitoring relevant product imports is the two-digit statistical code part of the National component. This may also be required when there are tariff codes in place, but they do not provide the refinement of product classification required for the government’s MEPS and labelling programme.

Table 11: Pakistan tariff codes for lamps for 2021-2022 (based on HS2017)

Tariff Code	Description	Duty (%)
<b>8539.10</b>	<b>Seal beam lamp units</b>	
853910.00	All	35
<b>8539.21</b>	<b>Other filament lamp (excl. ultra-violet or infra-red): Tungsten halogen</b>	
853921.10	Bulbs for automatic vehicles	35
853921.90	Other	11
<b>8539.22</b>	<b>Other filament lamp (excl. ultra-violet or infra-red): Other of power ≤200 W and for a voltage &gt;100 V</b>	
853922.00	All	20
<b>8539.29</b>	<b>Other filament lamp (excl. ultra-violet or infra-red): Other</b>	
853929.10	For automotive vehicles	35
853929.20	For flash light	20
853929.90	Other	20
<b>8539.31</b>	<b>Discharge lamps other than ultra-violet lamps: fluorescent, hot cathode</b>	
853931.10	Energy saving lamp	3
853931.20	Energy saving tube	3
853931.90	Other	20
<b>8539.32</b>	<b>Discharge lamps other than ultra-violet lamps: Mercury or sodium vapour lamps; metal halide lamps</b>	
853932.10	Energy saving lamp	3
853932.20	Energy saving tube	3
853932.90	Other	20
<b>8539.39</b>	<b>Discharge lamps other than ultra-violet lamps: Other</b>	
853939.00	All	20
<b>8539.41</b>	<b>Ultra-violet or infra-red lamps; arc-lamps: Arc lamps</b>	
853941.00	All	20
<b>8539.49</b>	<b>Ultra-violet or infra-red</b>	
853949.10	Infra-red lamps	20
853949.20	Ultraviolet lamps	20
<b>8539.50</b>	<b>Light-emitting diode (LED) lamps:</b>	
853950.10	Bulb	3
853950.20	Tube	3
<b>8539.90</b>	<b>Lamp Parts</b>	
853990.10	Tungsten filament and lead in wire for bulbs and tube lights	0
853990.20	Base cap for bulb	0
853990.30	Base cap for tube light	3
853990.40	Parts for energy saving lamps	0
853990.90	Other	3

## 6 IMPORT STATISTICS TO TRACK TRANSFORMATION OF MARKET TO LEDS

As stated previously, HS codes are a very effective means for monitoring trade statistics of commodities associated with energy efficient lighting regulations in a country.

The greatest benefit in monitoring import statistics arises for countries with limited local manufacturing of lighting products or at least products suitable for specific sectors of the lighting market. This is because products manufactured and sold locally do not pass through the country's border control and therefore do not get reported to Customs. It is also important to appreciate that many countries have no local production of lamps but have some local production or assembly of luminaires where the key components (e.g., LED chips/packages and drivers) may be imported. Trade statistics on these key components will provide some information on the level of local manufacturing/assembly of the finished products.

Effective analysis of import data for market monitoring purposes requires two main elements:

- An understanding of the latest HS classification refinements (and associated HS code changes) as discussed in 5.3.
- Appreciating how different traditional lamp technology sectors are adopting LED technology and the resulting changes to lamp and luminaire product forms.

### 6.1 Market transformation impact on analysis of lamp imports

The information about product end-use gained from monitoring the import of lamps using just their six-digit HS code is declining due to the market ultimately transforming exclusively to LED technology-based lighting products, as illustrated in Figure 9. Filament, fluorescent and high intensity discharge lamps are all being replaced by LED lamps, or the entire lamp-based (i.e., with lamp sockets) luminaire is being replaced by an integrated LED luminaire.

Figure 9: Examples of lamp types (with HS codes) before and after market transition to energy efficient products

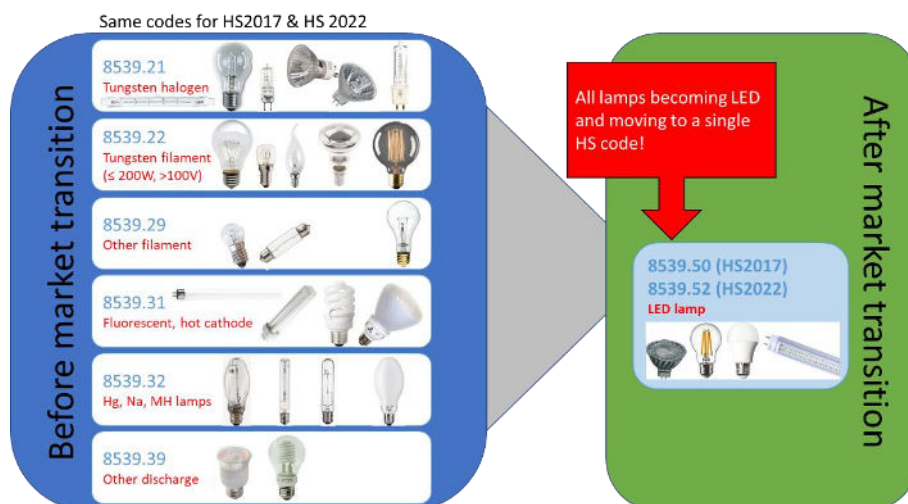

Also, traditional light source technologies (with their separate six-digit HS codes) are typically suited to different market sectors based on having different ranges of light output. Filament lamps and compact fluorescent lamps have low light output suitable predominantly for the domestic sector, tubular fluorescent lamps have mid-range light output that is suitable predominantly for the commercial sector and high intensity discharge lamps have high-range light output that is suitable predominantly for the industrial and public lighting sectors. So, as markets transition, all sectors will eventually have LED lamps with the same six-digit HS code, thereby losing information about each individual sector. This is illustrated in Figure 10.

Figure 10: A single LED lamp HS code replacing many HS codes for older lamp technologies typifying different market sectors

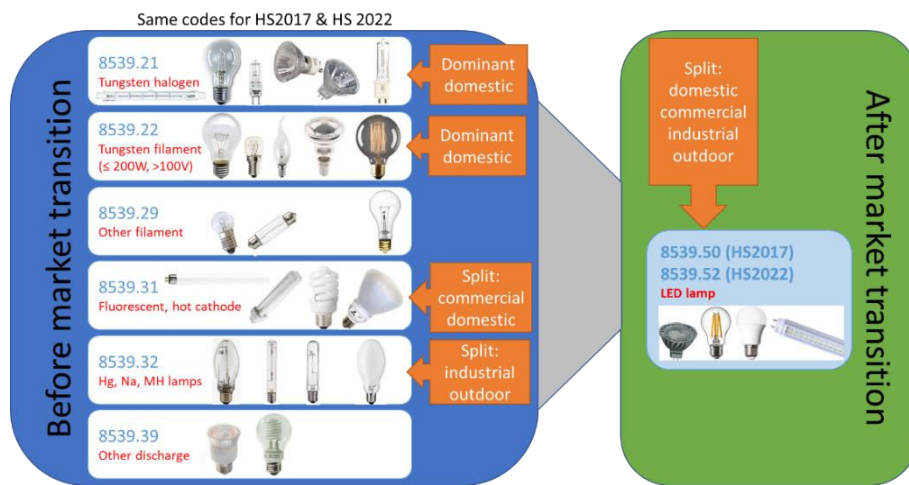

This phenomenon is demonstrated by import figures at the six-digit HS code level for lamps into Australia over the last ten years shown in Figure 11.

Figure 11: Import figures for the main lamp types at the six-digit HS code level

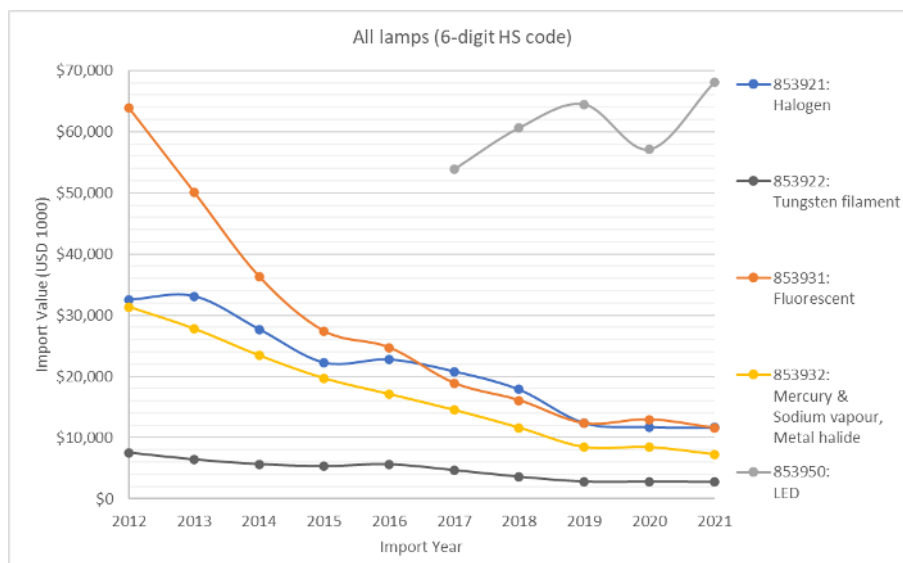

While the market transition is continuing, it is useful to be able to monitor the speed of transition in each of lamp technologies to provide evidential support to decisions on the revision or expansion of energy efficient lighting programmes. This requires refinement of lamp classification beyond the international six-digit HS code. Some countries have achieved this by segregating lamp technologies, assigning each a national tariff code. An example of the granularity provided to trade data analysis is presented in Figure 12, using Australian import data with illustrative national tariff codes (i.e., numerical codes have been produced for this example only, and do not reflect current national tariff codes in place). The additional information gained by use of national tariff codes pertains to the separation of compact fluorescent lamps from linear fluorescent tubes, and LED lamps (single cap) from linear LED tubes.

Figure 12: Import figures for refined lamp types, based on tariff codes at the eight-digit level

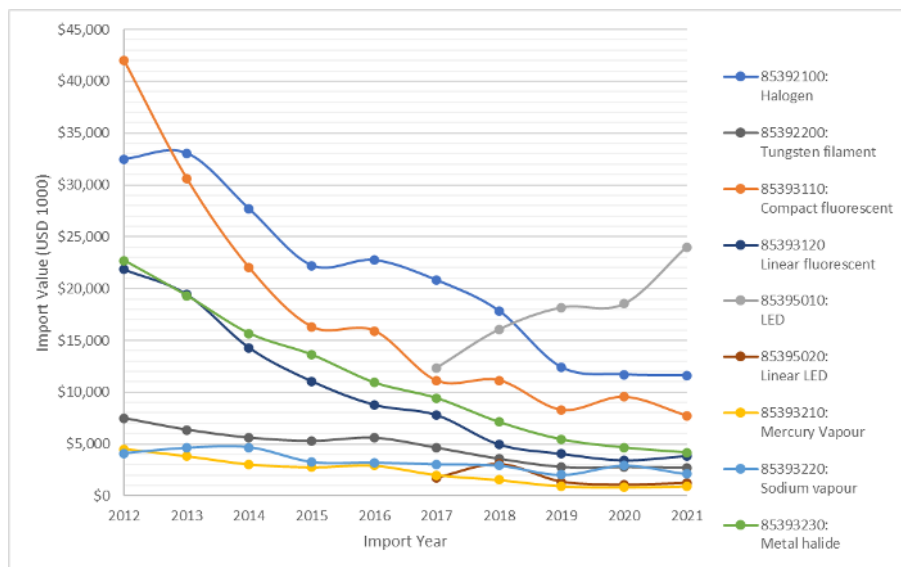

## 6.2 Market transformation impact on import analysis of luminaires

The market transformation to energy efficient LED luminaires is characterised by the transition from lamp-based luminaires (i.e., those with lamp sockets and typically with a separate ballast specific to the lamp technology and wattage) to those with an LED module (either fully integrated or with an electrical connector) so that a conventional lamp cannot physically be inserted.

In terms of monitoring the market's sector-by-sector transformation for luminaires, HS2017 provided very limited information to assist, because the six-digit HS codes only differentiate indoor from outdoor public space luminaires without any light source technology segregation for both. Specifically, for HS2017, the same HS codes applied (i.e., no change) to integrated LED and non-LED luminaires for these two market sectors. This is illustrated in Figure 13.

Figure 13: HS2017 version - Luminaire types before and after transition to energy efficient products showing no change to HS code.

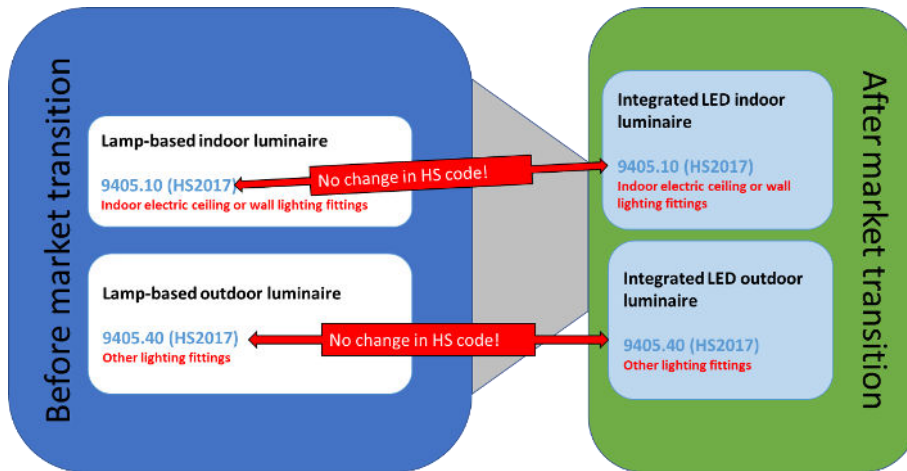

The revisions in HS2022 have improved the situation by further refining luminaire classifications at the second-tier Subheading level. As a result of the changes, moving forward from 1<sup>st</sup> January 2022, LED luminaires (i.e., those which cannot have a conventional lamp inserted) can be segregated from traditional luminaires with lamp holders, providing valuable market transformation information, as shown in Figure 14. This was previously illustrated in the annual import data trend graph for indoor luminaires in Figure 8, where this separation of data in 2022 was discussed.

Figure 14: HS2022 segregation of luminaire types identifying the transition to energy efficient products with a unique HS code for integrated LED products

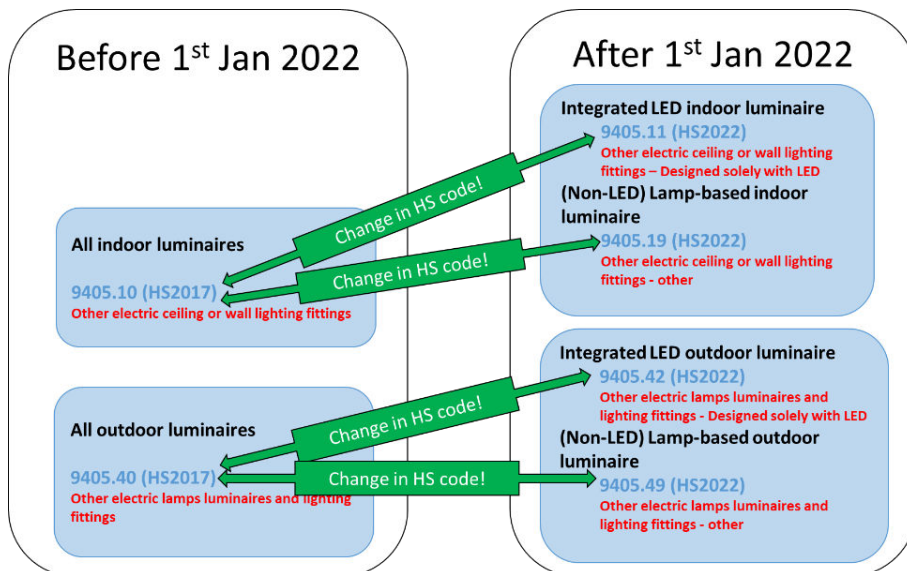

## 7 DEVELOPING NATIONAL STATISTICAL CODES

Regulatory programmes in energy efficient lighting vary in scope ranging from the very limited (e.g., non-directional filament, compact fluorescent, and LED lamps only) to the all-encompassing (e.g., all light sources, lamps, and luminaires). For the last three decades, the development of such programmes has been instigated by the transformation of the market, driven mainly by energy efficiency improvements due to the progress of light source technologies. This light source transition to LEDs has also shaped the move from lamp-based luminaires to luminaires with fully integrated LED light sources.

The capability to monitor the rate of transition in different market sectors for countries that largely import lighting products, relies heavily on tracking import data at levels detailed enough to provide clear trends in lamp technology and luminaire types. This section provides guidance on how to develop such classification refinements at the statistical code level as part of the national component of the commodity code.

### 7.1 Identification of the required data refinement

Expanding the product scope or monitoring the impact of an existing programme requires the ability to obtain detailed trend data on the transformation in particular market sectors. This can be done by identifying specific lamp and luminaire types which are representative of the sectors of interest, due to those product types having a significant portion of the installations of that sector.

However, examination of the six-digit HS codes for sector-representative products highlights that the sought-after trade data cannot be extracted as some of the products are subsets of broader commodity groupings at the six-digit HS code level. Therefore, once identified, these products should be segregated from other lamp or luminaire types by creating new classifications at the statistical code level within the national component. The trade data at these 10-digit code levels will then provide robust information on the rate of transformation of the sectors they represent.

### 7.2 Data refinement for lamps

Market transformation to energy efficiency lighting in the domestic sector is evidenced by the historical transition in lamp technology: from tungsten filament lamps to halogen lamps, then to compact fluorescent lamps, and on to LED lamps. In the commercial lighting sector, linear lamp technology progression has moved from halo-phosphor to tri-phosphor fluorescent tubes, and then to LED tubes. In the industrial and outdoor lighting sectors, the lamp technology progression has been mercury vapour, sodium vapour, metal halide to LED.

At the international six-digit HS code level, the main loss of data for representative lamps in the domestic and commercial market sectors is due to there being no separation (as discussed in at the end of Section 6.1) of compact fluorescent lamps from linear fluorescent tubes, and LED lamps (single cap) from linear LED tubes, as illustrated in Figure 15. The (double cap) tubes are representative of, and dominant in, commercial installations and likewise for single cap lamps in residential installations.



Figure 15: Lack of refinement for fluorescent and LED lamp types based on market sectors

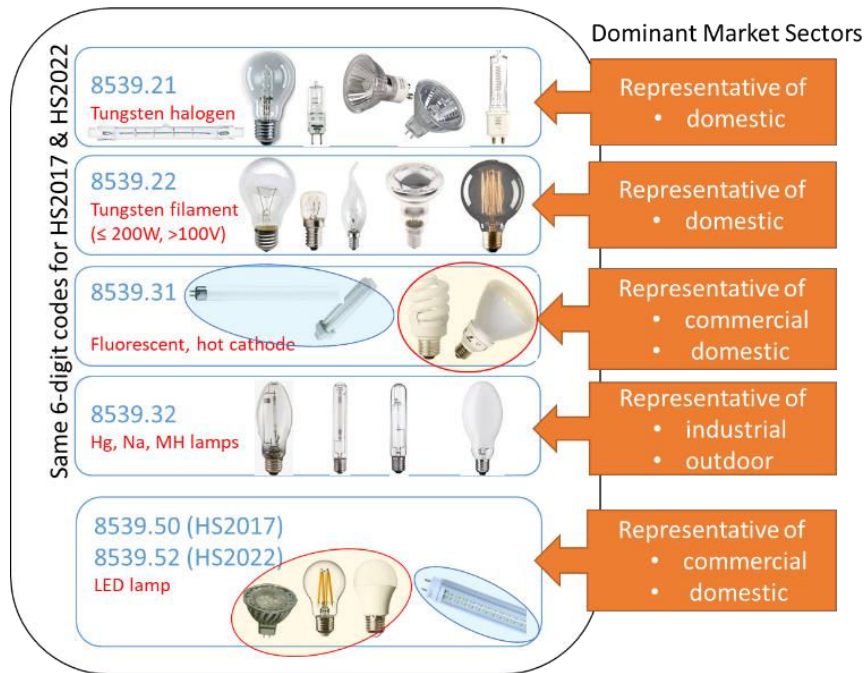

Inspection of the different compact fluorescent lamps reveals that there are self-ballasted forms (CFL<sub>i</sub>), the prevalent form in the domestic sector, and non-ballasted forms (CFL<sub>ni</sub>) mainly found in the commercial sector (but less prevalent). To improve the quality of intended data trends, it would be prudent to separate these two groups. If the CFL<sub>ni</sub> data is not seen as very valuable to the programme, then there is no need to create a separate classification for them. If they are excluded, by the description, from the desired classifications, they will be accounted for in the catch-all remaining product classification “other”.

Also, linear lamps can be double cap and single cap (sometimes referred to as “U” tube). Again, if it is desirable to not include “U” tubes as part of a representative linear lamp group for the commercial sector, they can be filtered out with a more confined description (e.g., only doubled-capped linear lamps).

Examples of new statistical codes separating the representative lamp types for fluorescent and LED lamps are provided in Table 12. Note that the Tariff code “00” is used to designate the same customs duty for all products. Table 8 in Section 0 provided an example where tariff codes separated product classes (for the purpose of varying customs duties) as well as there being a different class separation with statistical codes.

Table 12: Creation of statistical codes for segregation of sector representative lamp types

Six-digit International Code						Four-digit National Code			
Chapter   Heading   Subheading						Tariff   <b>Statistical</b>			
A	A	B	B	C <sub>1</sub>	C <sub>2</sub>	D <sub>1</sub>	D <sub>2</sub>	E <sub>1</sub>	E <sub>2</sub>
8539.3: Discharge lamps, other than ultra-violet lamps:									
8539.31: – Fluorescent, hot cathode									
Double cap straight type						0	0	1	0
Self-ballasted compact fluorescent type						0	0	4	0
Other						0	0	9	0
8539.5: Light emitting diode (LED) light sources:									
8539.52: – Light emitting diode (LED) lamp									
Double cap straight type						0	0	1	0
Single cap integrated control gear type						0	0	4	0
Other						0	0	9	0

If there is a wish to retain separate trade data for single cap linear “U” tubes and non-ballasted compact fluorescent lamps, CFL<sub>ni</sub>, additional statistical codes would need to be created within 853931 and 853952 for the fluorescent and equivalent LED forms of these lamp types.

In Table 12, these examples of creating useful statistical code commodity subsets within a six-digit HS code have all been illustrated with a single tariff code of “00” for each, indicating a single excise duty for all products within. As stated previously, if there are multiple tariffs within a six-digit HS code, then the statistical code segregation comes after the eight-digit tariff level. This creates the ability for statistical code segregation after the tariff, as illustrated in Table 11. In that example, tungsten filament lamps (853922) all have the same excise duty (single tariff code = 00) but hot cathode fluorescent lamps (853931) have three different excise duties dependent on their type (tariff codes: 10 = CFL, 20 = LFL, 90 = other). The statistical code segregation can be the same for all, some or none of the tariff codes depending on the desired data to be collected.

A country may introduce a quite restricted product scope for their first energy efficient appliance or lighting regulation. The smaller scope helps with the establishment of systems, resources, and expertise within the government agencies before expanding to a broader product scope. An example of such a restricted scope is regulating non-directional lamps only. In this situation, trade data refinement will be necessary within most of the lamp specific six-digit HS codes, as identified below in Figure 16, to segregate directional and linear lamps from non-directional lamps by creating National Statistical codes.

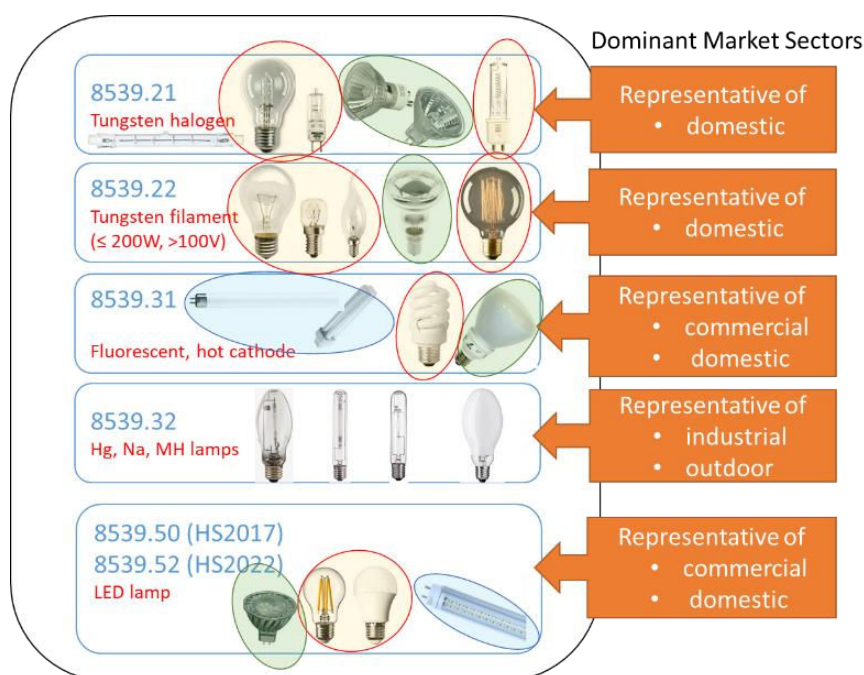

Figure 16: The need for segregation of non-directional (circled in red) from directional (circled in green) and linear lamps (circled in blue) within the six-digit HS codes









### 7.3 Data refinement for luminaires

Although HS2022 now makes it possible to understand the import data split between integrated LED luminaires and lamp-based luminaires (which are predominantly non-LED lamp forms), this is not sufficient for close monitoring of sector-by-sector market transformation. Therefore, representative luminaire types are required for each sector with their own statistical code. This lack of differentiation between the sectors is illustrated by the examples of market sector representative luminaire types provided in Table 13.

Table 13: Examples of representative luminaire types (and HS codes) for different market sectors

Market Sector	Luminaire Type	Example Illustration and Six-digit HS Code	
		Non-LED form	LED form
Residential	Downlight		
	HS2017	9405.10 Chandeliers and other electric ceiling or wall lighting fittings, excluding those of a kind used for lighting public open spaces or thoroughfares	
	HS2022	9405.1 Chandeliers and other electric ceiling or wall lighting fittings, excluding those of a kind used for lighting public open spaces or thoroughfares:	
		9405.19 Other	

Market Sector	Luminaire Type	Example Illustration and Six-digit HS Code	
		Non-LED form	LED form
			Designed for use solely with light-emitting diode (LED) light sources
Commercial	Linear fluorescent batters and troffers		
		HS2017	9405.10 Chandeliers and other electric ceiling or wall lighting fittings, excluding those of a kind used for lighting public open spaces or thoroughfares
	HS2022	9405.1 Chandeliers and other electric ceiling or wall lighting fittings, excluding those of a kind used for lighting public open spaces or thoroughfares:	
		9405.19 Other	9405.11 Designed for use solely with light-emitting diode (LED) light sources
Industrial	High Bay & Low Bay		
		HS2017	9405.10 Chandeliers and other electric ceiling or wall lighting fittings, excluding those of a kind used for lighting public open spaces or thoroughfares
	HS2022	9405.1 Chandeliers and other electric ceiling or wall lighting fittings, excluding those of a kind used for lighting public open spaces or thoroughfares:	
		9405.19 Other	9405.11 Designed for use solely with light-emitting diode (LED) light sources
Outdoor	Roadway		
		HS2017	9405.40 Other electric lamps and lighting fittings
	HS2022	9405.4 Other electric luminaires and lighting fittings:	
		9405.49 Other	9405.41 Photovoltaic, designed for use solely with light-emitting diode (LED) light sources
			9405.42 Other, designed for use solely with light-emitting diode (LED) light sources

From these examples, it is clear that the international six-digit HS codes for the representative indoor luminaires for residential, commercial, and industrial sectors are the same, with only a partition between integrated LED from non-integrated luminaires in the 2022 version. Roadway luminaires are separated from indoor luminaires but are categorised the same (i.e., same 6-digit HS code) as all other outdoor public space luminaires such as park lighting. There is an additional segregation of LED luminaires between solar powered and mains power supplied luminaires.

Examples of new statistical codes that could be used to separate all the representative luminaire types with segregation between integrated LED from non-integrated luminaires are provided in Table 14 and Table 15 for HS2022.

Table 14: Creation of statistical codes for segregation of sector representative indoor luminaire types

Six-digit International Code						Four-digit National Code			
Chapter   Heading   Subheading						Tariff   <b>Statistical</b>			
A	A	B	B	C <sub>1</sub>	C <sub>2</sub>	D <sub>1</sub>	D <sub>2</sub>	E <sub>1</sub>	E <sub>2</sub>
9405.1: Chandeliers and other electric ceiling or wall lighting fittings, excluding those of a kind used for lighting public open spaces or thoroughfares:									
<b>9405.11:</b> – Designed for use solely with light-emitting diode (LED) light sources									
Industrial:								1	
High bay, low bay						0	0	1	1
Outdoor floodlight						0	0	1	2
Other						0	0	1	9
Indoor other than industrial:								2	
Downlights						0	0	2	1
Panel, batten, troffer (replacing linear fluorescent luminaires)						0	0	2	2
Other						0	0	2	9
Other						0	0	9	0
<b>9405.19:</b> – Other									
Industrial:								1	
High bay, low bay						0	0	1	1
Outdoor floodlight						0	0	1	2
Other						0	0	1	9
Indoor other than industrial:								2	
Downlights						0	0	2	1
Panel, batten, troffer (replacing linear fluorescent luminaires)						0	0	2	2
Other						0	0	2	9
Other						0	0	9	0

Table 15: Creation of statistical codes for segregation of sector representative roadway luminaires

Six-digit International Code						Four-digit National Code			
Chapter   Heading   Subheading						Tariff   <b>Statistical</b>			
A	A	B	B	C <sub>1</sub>	C <sub>2</sub>	D <sub>1</sub>	D <sub>2</sub>	E <sub>1</sub>	E <sub>2</sub>
9405.4: Other electric luminaires and lighting fittings:									
9405.41: – Photovoltaic, designed for use solely with light-emitting diode (LED) light sources									
Roadway luminaire						0	0	1	0
Other						0	0	9	0
9405.42: – Other, designed for use solely with light-emitting diode (LED) light sources									
Roadway luminaire						0	0	1	0
Other						0	0	9	0

### 7.4 Data refinement for lamp and luminaire components

Many countries have established a thriving local manufacturing and assembly industry for LED lamps and luminaires. The size and output of the local industry can provide opportunities for supporting programmes and policy direction for energy efficient lighting regulatory programmes. The stimulus could include activities such as tax incentives for assembly plant upgrades, training or export business awareness. Monitoring the import data for the key components in the production of local LED lamps and luminaires can provide valuable information for establishing well-targeted activities.

HS2022 provides an improved segregation of some of these key components compared to the HS2017 classification where they were all subsets of larger commodity groups. LED chips/packages and LED modules now have been assigned their own separate unique six-digit HS codes, whereas LED drivers are still a subset in a larger classification of “static converters”, as illustrated in Figure 17.

Figure 17: Key components imported for product assembly with their own six-digit HS codes in HS2022

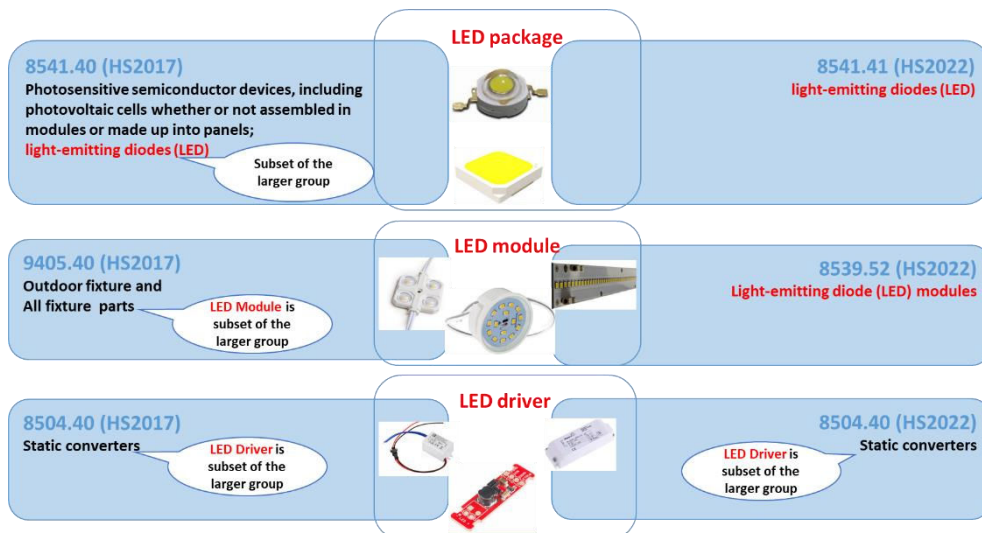

Examples of new statistical codes that could be used to separate LED drivers from all other static drivers are provided in Table 16.

Table 16: Creation of statistical codes for segregation of sector representative roadway luminaires

Six-digit International Code						Four-digit National Code			
Chapter   Heading   Subheading						Tariff   <b>Statistical</b>			
A	A	B	B	C <sub>1</sub>	C <sub>2</sub>	D <sub>1</sub>	D <sub>2</sub>	E <sub>1</sub>	E <sub>2</sub>
8504: Electrical transformers, static converters (for example, rectifiers) and inductors:									
8504.40: Static converters:									
Light-emitting diode (LED) drivers						0	0	1	0
Other						0	0	9	0

### Example country scenario for creation of statistical codes for lighting products

The scope of a country's MEPS on lighting products will play a part in determining the segregation of products that is desired beyond the six-digit international HS code to best support robust monitoring, verification and enforcement (MVE) activities. Also, the review and update of energy efficient lighting policy and programmes will benefit from a strategic consideration for an extended (beyond any existing MEPS scope) commodity segregation that will provide comprehensive data as part of monitoring, reporting and verification (MRV) practices to support future policy directions and programme expansion.

The following example scenario explains the creation of statistical codes for segregating lighting commodities for a fictitious country while achieving the desired objectives of supporting both:

- MVE for an existing MEPS scope.
- MRV for energy efficient lighting future policy directions and programme expansion.

A country has implemented a MEPS consistent with the U4E Model Regulation Guidelines, "[Energy Efficiency and Functional Performance Requirements for General Service Lamps](#)"<sup>11</sup>. This Regulation applies to all types (shapes and finishes) of general service lamps for general illumination purposes using incandescent, halogen, fluorescent, or light emitting diode (LED) light sources, and having:

- a) one or more input voltages of alternating current between 50 and 300 V and frequency of 50 Hz or 60 Hz, and
- b) a lamp base which can be connected to one of the following general service lamp sockets:
  - screw base types: E10, E11, E12, E14, E17, E26 or E27, or
  - bayonet base types: B15d or B22d, or
  - pin base types: GU10 or GZ10 base, or
  - alternative base types which can be connected to the above lamp base sockets by using commercially available passive adaptors.

<sup>11</sup><https://united4efficiency.org/resources/model-regulation-guidelines-for-energy-efficiency-and-functional-performance-requirements-for-general-service-lamps/>

To assist with the country’s MVE activities, statistical codes could be established to segregate six-digit HS code classifications, where necessary into:

- Non-directional and directional lamps.
- Extra-low voltage and mains voltage operated lamps.
- Double capped and single capped lamps.

The statistical codes that create the desired separation of products within scope of MEPS from those outside of scope for the different lamp technologies are the following reference line numbers (Ref line #) in Table 17. (Note that some of the functional segregation of LED lamps is for the example scenario described in Section 7.5)

- 8539.21 Tungsten halogen lamps: Reference line numbers: 13 – 18
- 8539.22 Tungsten filament lamps: Reference line numbers: 20 – 21
- 8539.31 Compact fluorescent lamps: Reference line numbers: 29 – 31
- 8539.52 LED lamps: Reference line numbers: 50 – 51, 53 – 62

Table 17: Statistical code creation for lamps

Chapter	including Heading	including Subheading	including Tariff code	including Statistical code	Units of Quantity	Description	Ref line #
85						<b>ELECTRICAL MACHINERY AND EQUIPMENT AND PARTS THEREOF SOUND RECORDERS AND REPRODUCERS, TELEVISION IMAGE AND SOUND RECORDERS AND REPRODUCERS, AND PARTS AND ACCESSORIES OF SUCH ARTICLES</b>	1
	8504					ELECTRICAL TRANSFORMERS, STATIC CONVERTERS, FOR EXAMPLE, RECTIFIERS, AND INDUCTORS:	2
		8504.10	850410.00	85041000.00	NO	- Ballasts for discharge lamps or tubes	3
		8504.40	850440.00		NO	- Static converters	4
				85044000.1		<i>Light-emitting diode (LED) Drivers:</i>	5
				85044000.11	NO	..Having a power handling capacity not exceeding 10 W	6
				85044000.12	NO	..Having a power handling capacity exceeding 10 W but not exceeding 25 W	7
				85044000.13	NO	..Having a power handling capacity exceeding 25 W	8
	8539					<b>ELECTRIC FILAMENT OR DISCHARGE LAMP INCLUDING SEALED BEAM LAMP UNITS AND ULTRA-VIOLET OR INFRA-RED LAMPS; ARC-LAMP</b>	9
		8539.2				<i>- Other filament lamps, excluding ultra-violet or infra-red lamps:</i>	10
		8539.21	853921.00			-- Tungsten halogen	11
				85392100.10	NO	..For motor vehicles	12
				85392100.2		<i>Reflector type:</i>	13
				85392100.21	NO	..Less than or equal to 50 V	14
				85392100.22	NO	..Greater than 50 V	15
				85392100.5		<i>Non-reflector type:</i>	16
				85392100.51	NO	..Less than or equal to 50 V	17
				85392100.52	NO	..Greater than 50 V	18
		8539.22	853922.00			-- Other, of a power not exceeding 200 W and for a voltage exceeding 100 V	19
				85392200.10	NO	..Reflector type	20
				85392200.50	NO	..Non-reflector type	21
		8539.29	853929.00	85392900.00	NO	-- Other	22
		8539.3				<i>- Discharge lamps, other than ultra-violet lamps:</i>	23
		8539.31	853931.00			-- Fluorescent, hot cathode	24
				85393100.1		<i>Straight type (including halophosphor and triphosphor) fluorescent discharge lamps:</i>	25
				85393100.11	NO	..Less than 550 mm nominal length	26
				85393100.12	NO	..Not less than 550 mm but not exceeding 1200 mm nominal length	27
				85393100.13	NO	..Exceeding 1200 mm nominal length	28
				85393100.2		<i>Compact fluorescent discharge lamps:</i>	29
				85393100.21	NO	..Integrated ballast type	30
				85393100.22	NO	..Other	31
				85393100.90	NO	..Other	32
		8539.32	853932.00			-- Mercury or sodium vapour lamps; metal halide lamps	33
				85393200.10	NO	..Mercury vapour lamps	34
				85393200.20	NO	..Sodium vapour lamps	35
				85393200.3		<i>Metal halide lamps:</i>	36
				85393200.31	NO	..Less than or equal to 200 W	37
				85393200.32	NO	..Greater than 200 W but not exceeding 400W	38
				85393200.33	NO	..Greater than 400 W	39
		8539.39	853939.00			-- Other	40
						<i>- Light-emitting diode (LED) light sources:</i>	44
						<i>--- LED (LED) modules</i>	45



	8539.39	85393200.33	INV			40
	8539.39	853939.00	NO		-- Other	44
	8539.5				- Light-emitting diode (LED) light sources:	44
	8539.51	853951.00			-- Light-emitting diode (LED) modules	45
		85395100.10	NO		..Less than or equal to 10 W	46
		85395100.20	NO		..Greater than 10 W but not exceeding 50W	47
		85395100.30	NO		..Greater than 50 W	48
	8539.52	853952.00	NO		-- Light-emitting diode (LED) lamps	49
		85395200.1			..Connected (WiFi, Bluetooth or similar) LED lamp:	50
		85395200.11	NO		...Single cap	51
		85395200.12	NO		...Double cap	52
		85395200.2			..Dimmable LED lamp:	53
		85395200.21	NO		...Directional lamp, not exceeding 50V	54
		85395200.22	NO		...Non-directional lamp, not exceeding 50V	55
		85395200.23	NO		...Directional lamp, exceeding 50V	56
		85395200.24	NO		...Non-directional lamp, not exceeding 50V	57
		85395200.3			..Non Dimmable LED lamp:	58
		85395200.31	NO		...Directional lamp, not exceeding 50V	59
		85395200.32	NO		...Non-directional lamp, not exceeding 50V	60
		85395200.33	NO		...Directional lamp, exceeding 50V	61
		85395200.34	NO		...Non-directional lamp, not exceeding 50V	62
		85395200.4			..LED Linear lamp with G13 or G5 cap:	63
		85395200.41	NO		...Less than 550 mm nominal length	64
		85395200.42	NO		...Not less than 550 mm but not exceeding 1200 mm nominal length	65
		85395200.43	NO		...Exceeding 1200 mm nominal length	66
		85395200.90	NO		..Other	67
	8539.90	853990.00	85399000.00	NO	- Parts	68
8541					SEMICONDUCTOR DEVICES (FOR EXAMPLE, DIODES, TRANSISTORS, SEMICONDUCTOR-BASED TRANSDUCERS); PHOTSENSITIVE SEMICONDUCTOR DEVICES, INCLUDING PHOTOVOLTAIC CELLS WHETHER OR NOT ASSEMBLED IN MODULES OR MADE UP INTO PANELS; LIGHT-EMITTING DIODES (LED), WHETHER OR NOT ASSEMBLED WITH OTHER LIGHT-EMITTING DIODES (LED); MOUNTED PIEZO-ELECTRIC CRYSTALS:	69
	8541.4				- Photosensitive semiconductor devices, including photovoltaic cells whether or not assembled in modules or made up into panels; light-emitting diodes (LED)	70
	8541.41	854141.00			--Light-emitting diodes (LED)	71
		85414100.1			..White light producing light-emitting diodes (LED), including LED chips, LED chip on board (COB), LED packages:	72
		85414100.11	NO		...Power rating not exceeding 1 W	73
		85414100.12	NO		...Power rating exceeding 1 W but not exceeding 10 W	74
		85414100.13	NO		...Power rating exceeding 10 W but not exceeding 50 W	75
		85414100.14	NO		...Power rating exceeding 50 W	76
		85414100.90	NO		..Other	77

## 7.5 Example country scenario for statistical code creation to support market sector and lighting product monitoring

Continuing with the fictitious example, the country’s current MEPS is for lamps predominant in the domestic sector. Future expansion of the MEPS scope could consider inclusion of lamps and luminaires from other sectors. To assist with the monitoring of the market transformations within each sector, representative product types with lumen/wattage ranges could be segregated into:

- Downlight luminaires (representative of the domestic and commercial sectors).
- Linear fluorescent and LED tubes (representative of the commercial sector).
- Linear fluorescent luminaires and LED equivalents (representative of the commercial sector).
- Different types of high intensity discharge lamps (representative of the industrial and outdoor sectors).
- High bay and low bay luminaires (representative of the industrial sector).
- Outdoor floodlight luminaires (representative of the industrial sector).
- Roadway luminaires.

The statistical codes that create the desired separation of the lamps are the following reference line numbers (Ref line #) in Table 17.

- 8539.31 Linear fluorescent lamps: Reference line numbers: 25 – 28
- 8539.22 High intensity discharge lamps: Reference line numbers: 33 – 39
- 8539.52 Linear LED lamps: Reference line numbers: 52, 63 – 66

The Statistical codes that create the desired separation of the luminaires are the following reference line numbers (Ref line #) in Table 18.

- Downlights
  - 9405.11 Integrated LED luminaires: Reference line numbers: 11 – 13
  - 9405.19 Non-LED luminaires: Reference line numbers: 25 – 27
- Linear fluorescent luminaires and LED equivalents
  - 9405.11 Integrated LED luminaires: Reference line numbers: 14 – 17
  - 9405.19 Non-LED luminaires: Reference line numbers: 28 – 30
- High bay and low bay luminaires
  - 9405.11 Integrated LED luminaires: Reference line numbers: 8
  - 9405.19 Non-LED luminaires: Reference line numbers: 22
- Outdoor floodlight luminaires
  - 9405.11 Integrated LED luminaires: Reference line numbers: 9
  - 9405.19 Non-LED luminaires: Reference line numbers: 23
- Roadway luminaires
  - 9405.41 Photovoltaic integrated LED luminaires: Reference line numbers: 32 – 33
  - 9405.42 Integrated LED luminaires: Reference line numbers: 36 – 37
  - 9405.49 Non-LED luminaires: Reference line numbers: 40 – 41

Table 18: Statistical code creation for luminaires

Chapter	including Heading	including Subheading	including Tariff code	including Statistical code	Units of Quantity	Description	Ref line #
94						FURNITURE; BEDDING, MATTRESSES, MATTRESS SUPPORTS, CUSHIONS AND SIMILAR STUFFED FURNISHINGS; LUMINAIRE AND LIGHTING FITTINGS, NOT ELSEWHERE SPECIFIED OR INCLUDED; ILLUMINATED SIGNS, ILLUMINATED NAME-PLATES AND THE LIKE; PREFABRICATED BUILDINGS	1
		9405				LUMINAIRE AND LIGHTING FITTINGS INCLUDING SEARCHLIGHTS AND SPOTLIGHTS AND PARTS THEREOF, NOT ELSEWHERE SPECIFIED OR INCLUDED; ILLUMINATED SIGNS, ILLUMINATED NAME-PLATES AND THE LIKE, HAVING A PERMANENTLY FIXED LIGHT SOURCE, AND PARTS THEREOF NOT ELSEWHERE SPECIFIED OR INCLUDED:	2
						- Chandeliers and other electric ceiling or wall lighting fittings, excluding those of a kind used for lighting public open spaces or thoroughfares:	3
		9405.11	940511.00			-- Designed for use solely with light-emitting diode (LED) light sources	4
				94051100.10	NO	.Chandeliers	5
				94051100.20	NO	.Emergency (including exit signs)	6
				94051100.3		.Industrial:	7
				94051100.31	NO	..Highbay or Lowbay	8
				94051100.32	NO	..Outdoor floodlight	9
				94051100.39	NO	..Other	10
				94051100.4		.Down lights:	11
				94051100.41	NO	..Not exceeding 15W	12
				94051100.42	NO	..Exceeding 15W	13
				94051100.5		.Designed as replacement for linear fluorescent luminaires:	14
				94051100.51	NO	..Panel (Planar) luminaires	15
				94051100.52	NO	..Batten or Troffer luminaires	16
				94051100.59	NO	..Other	17
		9405.19	940519.00			-- Other	18
				94051900.10	NO	.Chandeliers	19
				94051900.20	NO	.Emergency (including exit signs)	20
				94051900.3		.Industrial:	21
				94051900.31	NO	..Highbay or Lowbay	22
				94051900.32	NO	..Outdoor floodlight	23
				94051900.39	NO	..Other	24
				94051900.4		.Down lights:	25
				94051900.41	NO	..Not exceeding 50W	26
				94051900.42	NO	..Exceeding 50W	27
				94051900.5		.Linear fluorescent luminaires:	28
				94051900.51	NO	..Batten or Troffer luminaires	29
				94051900.59	NO	..Other	30
		9405.4				- Other electric luminaires and lighting fittings:	31
		9405.41	940541.00			-- Photovoltaic, designed for use solely with light-emitting diode (LED) light sources	32
				94054100.10	NO	.Roadway luminaires	33
				94054100.20	NO	.Public space luminaires:	34
				94054100.30	NO	.Other	35
		9405.42	940542.00			-- Other, designed for use solely with light-emitting diode (LED) light sources	36
				94054200.10	NO	.Roadway luminaires	37
				94054200.20	NO	.Public space luminaires:	38
				94054200.30	NO	.Other	39
		9405.49	940549.00			-- Other	40
				94054900.10	NO	.Roadway luminaires	41
				94054900.20	NO	.Public space luminaires:	42
				94054900.30	NO	.Other	43

## 8 Annex A: Chapter numbers and descriptions within Sections of HS2022

SECTION I: LIVE ANIMALS; ANIMAL PRODUCTS		Full six-digit HS code descriptions
Chapter	Description	Web link
1	Live animals.	<a href="#">0101-2022E</a>
2	Meat and edible meat offal.	<a href="#">0102-2022E</a>
3	Fish and crustaceans, molluscs and other aquatic invertebrates.	<a href="#">0103-2022E</a>
4	Dairy produce; birds' eggs; natural honey; edible products of animal origin, not elsewhere specified or included.	<a href="#">0104-2022E</a>
5	Products of animal origin, not elsewhere specified or included.	<a href="#">0105-2022E</a>
SECTION II: VEGETABLE PRODUCTS		Full six-digit HS code descriptions
Chapter	Description	Web link
6	Live trees and other plants; bulbs, roots and the like; cut flowers and ornamental foliage.	<a href="#">0206-2022E</a>
7	Edible vegetables and certain roots and tubers.	<a href="#">0207-2022E</a>
8	Edible fruit and nuts; peel of citrus fruit or melons.	<a href="#">0208-2022E</a>
9	Coffee, tea, maté and spices.	<a href="#">0209-2022E</a>
10	Cereals.	<a href="#">0210-2022E</a>
11	Products of the milling industry; malt; starches; inulin; wheat gluten.	<a href="#">0211-2022E</a>
12	Oil seeds and oleaginous fruits; miscellaneous grains, seeds and fruit; industrial or medicinal plants; straw and fodder.	<a href="#">0212-2022E</a>
13	Lac; gums, resins and other vegetable saps and extracts.	<a href="#">0213-2022E</a>
14	Vegetable plaiting materials; vegetable products not elsewhere specified or included.	<a href="#">0214-2022E</a>
SECTION III ANIMAL, VEGETABLE OR MICROBIAL FATS AND OILS AND THEIR CLEAVAGE PRODUCTS; PREPARED EDIBLE FATS; ANIMAL OR VEGETABLE WAXES		Full six-digit HS code descriptions
Chapter	Description	Web link
16	Preparations of meat, of fish, of crustaceans, molluscs or other aquatic invertebrates, or of insects.	<a href="#">0416-2022E</a>
17	Sugars and sugar confectionery.	<a href="#">0417-2022E</a>
18	Cocoa and cocoa preparations.	<a href="#">0418-2022E</a>
19	Preparations of cereals, flour, starch or milk; pastrycooks' products.	<a href="#">0419-2022E</a>
20	Preparations of vegetables, fruit, nuts or other parts of plants.	<a href="#">0420-2022E</a>
21	Miscellaneous edible preparations.	<a href="#">0421-2022E</a>
22	Beverages, spirits and vinegar.	<a href="#">0422-2022E</a>
23	Residues and waste from the food industries; prepared animal fodder.	<a href="#">0423-2022E</a>
24	Tobacco and manufactured tobacco substitutes; products, whether or not containing nicotine, intended for inhalation without combustion; other nicotine containing products intended for the intake of nicotine into the human body.	<a href="#">0424-2022E</a>

SECTION V MINERAL PRODUCTS		Full six-digit HS code descriptions
Chapter	Description	Web link
25	Salt; sulphur; earths and stone; plastering materials, lime and cement.	<a href="#">0525-2022E</a>
26	Ores, slag and ash.	<a href="#">0526-2022E</a>
27	Mineral fuels, mineral oils and products of their distillation; bituminous substances; mineral waxes.	<a href="#">0527-2022E</a>
SECTION VI PRODUCTS OF THE CHEMICAL OR ALLIED INDUSTRIES		Full six-digit HS code descriptions
Chapter	Description	Web link
28	Inorganic chemicals; organic or inorganic compounds of precious metals, of rare-earth metals, of radioactive elements or of isotopes.	<a href="#">0628-2022E</a>
29	Organic chemicals.	<a href="#">0629-2022E</a>
30	Pharmaceutical products.	<a href="#">0630-2022E</a>
31	Fertilisers.	<a href="#">0631-2022E</a>
32	Tanning or dyeing extracts; tannins and their derivatives; dyes, pigments and other colouring matter; paints and varnishes; putty and other mastics; inks.	<a href="#">0632-2022E</a>
33	Essential oils and resinoids; perfumery, cosmetic or toilet preparations.	<a href="#">0633-2022E</a>
34	Soap, organic surface-active agents, washing preparations, lubricating preparations, artificial waxes, prepared waxes, polishing or scouring preparations, candles and similar articles, modelling pastes, "dental waxes" and dental preparations with a basis of plaster.	<a href="#">0634-2022E</a>
35	Albuminoidal substances; modified starches; glues; enzymes.	<a href="#">0635-2022E</a>
36	Explosives; pyrotechnic products; matches; pyrophoric alloys; certain combustible preparations.	<a href="#">0636-2022E</a>
37	Photographic or cinematographic goods.	<a href="#">0637-2022E</a>
38	Miscellaneous chemical products.	<a href="#">0638-2022E</a>
SECTION VII PLASTICS AND ARTICLES THEREOF; RUBBER AND ARTICLES THEREOF		Full six -digit HS code descriptions
Chapter	Description	Web link
39	Plastics and articles thereof.	<a href="#">0739-2022E</a>
40	Rubber and articles thereof.	<a href="#">0740-2022E</a>
SECTION VIII RAW HIDES AND SKINS, LEATHER, FURSKINS AND ARTICLES THEREOF; SADDLERY AND HARNESS; TRAVEL GOODS, HANDBAGS AND SIMILAR CONTAINERS; ARTICLES OF ANIMAL GUT (OTHER THAN SILK-WORM GUT)		Full six -digit HS code descriptions
Chapter	Description	Web link
41	Raw hides and skins (other than furskins) and leather.	<a href="#">0841-2022E</a>
42	Articles of leather; saddlery and harness; travel goods, handbags and similar containers; articles of animal gut (other than silk-worm gut).	<a href="#">0842-2022E</a>
43	Furskins and artificial fur; manufactures thereof.	<a href="#">0843-2022E</a>

SECTION IX WOOD AND ARTICLES OF WOOD; WOOD CHARCOAL; CORK AND ARTICLES OF CORK; MANUFACTURES OF STRAW, OF ESPARTO OR OF OTHER PLAITING MATERIALS; BASKETWARE AND WICKERWORK		Full six -digit HS code descriptions
Chapter	Description	Web link
44	Wood and articles of wood; wood charcoal.	<a href="#">0844-2022E</a>
45	Cork and articles of cork.	<a href="#">0845-2022E</a>
46	Manufactures of straw, of esparto or of other plaiting materials; basketware and wickerwork.	<a href="#">0846-2022E</a>
SECTION X PULP OF WOOD OR OF OTHER FIBROUS CELLULOSIC MATERIAL; RECOVERED (WASTE AND SCRAP) PAPER OR PAPERBOARD; PAPER AND PAPERBOARD AND ARTICLES THEREOF		Full six -digit HS code descriptions
Chapter	Description	Web link
47	Pulp of wood or of other fibrous cellulosic material; recovered (waste and scrap) paper or paperboard.	<a href="#">0847-2022E</a>
48	Paper and paperboard; articles of paper pulp, of paper or of paperboard.	<a href="#">0848-2022E</a>
49	Printed books, newspapers, pictures and other products of the printing industry; manuscripts, typescripts and plans.	<a href="#">0849-2022E</a>
SECTION XI TEXTILES AND TEXTILE ARTICLES		Full six -digit HS code descriptions
Chapter	Description	Web link
50	Silk.	<a href="#">1150-2022E</a>
51	Wool, fine or coarse animal hair; horsehair yarn and woven fabric.	<a href="#">1151-2022E</a>
52	Cotton.	<a href="#">1152-2022E</a>
53	Other vegetable textile fibres; paper yarn and woven fabrics of paper yarn.	<a href="#">1153-2022E</a>
54	Man-made filaments; strip and the like of man-made textile materials.	<a href="#">1154-2022E</a>
55	Man-made staple fibres.	<a href="#">1155-2022E</a>
56	Wadding, felt and nonwovens; special yarns; twine, cordage, ropes and cables and articles thereof.	<a href="#">1156-2022E</a>
57	Carpets and other textile floor coverings.	<a href="#">1157-2022E</a>
58	Special woven fabrics; tufted textile fabrics; lace; tapestries; trimmings; embroidery.	<a href="#">1158-2022E</a>
59	Impregnated, coated, covered or laminated textile fabrics; textile articles of a kind suitable for industrial use.	<a href="#">1159-2022E</a>
60	Knitted or crocheted fabrics.	<a href="#">1160-2022E</a>
61	Articles of apparel and clothing accessories, knitted or crocheted.	<a href="#">1161-2022E</a>
62	Articles of apparel and clothing accessories, not knitted or crocheted.	<a href="#">1162-2022E</a>
63	Other made up textile articles; sets; worn clothing and worn textile articles; rags.	<a href="#">1163-2022E</a>

SECTION XII FOOTWEAR, HEADGEAR, UMBRELLAS, SUN UMBRELLAS, WALKING-STICKS, SEAT-STICKS, WHIPS, RIDING-CROPS AND PARTS THEREOF; PREPARED FEATHERS AND ARTICLES MADE THEREWITH; ARTIFICIAL FLOWERS; ARTICLES OF HUMAN HAIR		Full six -digit HS code descriptions
Chapter	Description	Web link
64	Footwear, gaiters and the like; parts of such articles.	<a href="#">1264-2022E</a>
65	Headgear and parts thereof.	<a href="#">1265-2022E</a>
66	Umbrellas, sun umbrellas, walking-sticks, seat-sticks, whips, riding-crops and parts thereof.	<a href="#">1266-2022E</a>
67	Prepared feathers and down and articles made of feathers or of down; artificial flowers; articles of human hair.	<a href="#">1267-2022E</a>
SECTION XIII ARTICLES OF STONE, PLASTER, CEMENT, ASBESTOS, MICA OR SIMILAR MATERIALS; CERAMIC PRODUCTS; GLASS AND GLASSWARE		Full six -digit HS code descriptions
Chapter	Description	Web link
68	Articles of stone, plaster, cement, asbestos, mica or similar materials.	<a href="#">1368-2022E</a>
69	Ceramic products.	<a href="#">1369-2022E</a>
70	Glass and glassware.	<a href="#">1370-2022E</a>
SECTION XIV NATURAL OR CULTURED PEARLS, PRECIOUS OR SEMI-PRECIOUS STONES, PRECIOUS METALS, METALS CLAD WITH PRECIOUS METAL AND ARTICLES THEREOF; IMITATION JEWELLERY; COIN		Full six -digit HS code descriptions
Chapter	Description	Web link
71	Natural or cultured pearls, precious or semi-precious stones, precious metals, metals clad with precious metal and articles thereof; imitation jewellery; coin.	<a href="#">1471-2022E</a>
SECTION XV BASE METALS AND ARTICLES OF BASE METAL		Full six -digit HS code descriptions
Chapter	Description	Web link
72	Iron and steel.	<a href="#">1572-2022E</a>
73	Articles of iron or steel.	<a href="#">1573-2022E</a>
74	Copper and articles thereof.	<a href="#">1574-2022E</a>
75	Nickel and articles thereof.	<a href="#">1575-2022E</a>
76	Aluminium and articles thereof.	<a href="#">1576-2022E</a>
77	(Reserved for possible future use in the Harmonized System)	<a href="#">1577-2022E</a>
78	Lead and articles thereof.	<a href="#">1578-2022E</a>
79	Zinc and articles thereof.	<a href="#">1579-2022E</a>
80	Tin and articles thereof.	<a href="#">1580-2022E</a>
81	Other base metals; cermets; articles thereof.	<a href="#">1581-2022E</a>
82	Tools, implements, cutlery, spoons and forks, of base metal; parts thereof of base metal.	<a href="#">1582-2022E</a>
83	Miscellaneous articles of base metal.	<a href="#">1583-2022E</a>

SECTION XVI MACHINERY AND MECHANICAL APPLIANCES; ELECTRICAL EQUIPMENT; PARTS THEREOF; SOUND RECORDERS AND REPRODUCERS, TELEVISION IMAGE AND SOUND RECORDERS AND REPRODUCERS, AND PARTS AND ACCESSORIES OF SUCH ARTICLES		Full six -digit HS code descriptions
Chapter	Description	Web link
84	Nuclear reactors, boilers, machinery and mechanical appliances; parts thereof.	<a href="#">1684-2022E</a>
85	Electrical machinery and equipment and parts thereof; sound recorders and reproducers, television image and sound recorders and reproducers, and parts and accessories of such articles.	<a href="#">1685-2022E</a>
SECTION XVII VEHICLES, AIRCRAFT, VESSELS AND ASSOCIATED TRANSPORT EQUIPMENT		Full 6-digit HS code descriptions
Chapter	Description	Web link
86	Railway or tramway locomotives, rolling-stock and parts thereof; railway or tramway track fixtures and fittings and parts thereof; mechanical (including electro-mechanical) traffic signalling equipment of all kinds.	<a href="#">1786-2022E</a>
87	Vehicles other than railway or tramway rolling-stock, and parts and accessories thereof.	<a href="#">1787-2022E</a>
88	Aircraft, spacecraft, and parts thereof.	<a href="#">1788-2022E</a>
89	Ships, boats and floating structures.	<a href="#">1789-2022E</a>
SECTION XVIII OPTICAL, PHOTOGRAPHIC, CINEMATOGRAPHIC, MEASURING, CHECKING, PRECISION, MEDICAL OR SURGICAL INSTRUMENTS AND APPARATUS; CLOCKS AND WATCHES; MUSICAL INSTRUMENTS		Full six -digit HS code descriptions
Chapter	Description	Web link
90	Optical, photographic, cinematographic, measuring, checking, precision, medical or surgical instruments and apparatus; parts and accessories thereof.	<a href="#">1890-2022E</a>
91	Clocks and watches and parts thereof.	<a href="#">1891-2022E</a>
92	Musical instruments; parts and accessories of such articles.	<a href="#">1892-2022E</a>
SECTION XIX ARMS AND AMMUNITION; PARTS AND ACCESSORIES THEREOF		
93	Arms and ammunition; parts and accessories thereof.	<a href="#">1993-2022E</a>
SECTION XX MISCELLANEOUS MANUFACTURED ARTICLES		Full six -digit HS code descriptions
Chapter	Description	Web link
94	Furniture; bedding, mattresses, mattress supports, cushions and similar stuffed furnishings; luminaires and lighting fittings, not elsewhere specified or included; illuminated signs, illuminated name-plates and the like; prefabricated buildings.	<a href="#">2094-2022E</a>
95	Toys, games and sports requisites; parts and accessories thereof.	<a href="#">2095-2022E</a>
96	Miscellaneous manufactured articles.	<a href="#">2096-2022E</a>
SECTION XXI WORKS OF ART, COLLECTORS' PIECES AND ANTIQUES		Full six -digit HS code descriptions
Chapter	Description	Web link
97	Works of art, collectors' pieces and antiques.	<a href="#">2197-2022E</a>



## 9 Annex B: HS2022 classifications for relevant lighting products

The full listing of Subheading classifications for Headings that include lighting products relevant to this guide within Chapter 85 and Chapter 94 are provided in Table 19 and Table 20 so the reader can follow the logical steps in the classification process (explained in Section 4.3) to arrive at the six-digit HS code for the specific lighting products.

To assist with clear identification of these lighting products, the text is colour-coded such that:

- **Red text** highlights the descriptor text
- **Green numbers** highlight the six-digit codes

Table 19: HS2022 Chapter 85 Headings with Subheading classifications for relevant lighting products

SECTION XVI	Machinery and mechanical appliances; <b>electrical equipment; parts thereof</b> ; sound recorders and reproducers, television image and sound recorders and reproducers, and parts and accessories of such articles
Chapter 85	<b>Electrical machinery and equipment and parts thereof</b> ; sound recorders and reproducers, television image and sound recorders and reproducers, and parts and accessories of such articles
85.04	Electrical transformers, <b>static converters</b> (for example, rectifiers) and inductors
<b>8504.10</b>	- <b>Ballasts for discharge lamps or tubes</b>
8504.2	- Liquid dielectric transformers:
8504.21	- Having a power handling capacity not exceeding 650 kVA
8504.22	- Having a power handling capacity exceeding 650 kVA but not exceeding 10 000 kVA
8504.23	- Having a power handling capacity exceeding 10 000 kVA
8504.3	- Other transformers:
8504.31	- Having a power handling capacity not exceeding 1 kVA
8504.32	- Having a power handling capacity exceeding 1 kVA but not exceeding 16 kVA
8504.33	- Having a power handling capacity exceeding 16 kVA but not exceeding 500 kVA
8504.34	- Having a power handling capacity exceeding 500 kVA
<b>8504.40</b>	- <b>Static converters</b>
8504.50	- Other inductors
8504.90	- Parts
85.39	<b>Electric filament or discharge lamps</b> , including sealed beam lamp units and ultra-violet or infra-red lamps; arc-lamps; <b>light-emitting diode (LED) lamps</b>
8539.10	- Sealed beam lamp units
8539.2	- Other filament lamps, excluding ultra-violet or infra-red lamps:
<b>8539.21</b>	- <b>Tungsten halogen</b>
<b>8539.22</b>	- <b>Other, of a power not exceeding 200 W and for a voltage exceeding 100V</b>

8539.29	- Other
8539.3	- Discharge lamps, other than ultra-violet lamps:
8539.31	- Fluorescent, hot cathode
8539.32	- Mercury or sodium vapour lamps; metal halide lamps
8539.39	- Other
8539.4	- Ultra-violet or infra-red lamps; arc-lamps:
8539.41	- Arc-lamps
8539.49	- Other
8539.5	- Light-emitting diode (LED) light sources:
8539.51	- Light-emitting diode (LED) modules
8539.52	- Light-emitting diode (LED) lamps
8539.90	- Parts
85.41	Diodes, transistors and similar semiconductor devices; photosensitive semiconductor devices, including photovoltaic cells whether or not assembled in modules or made up into panels; light-emitting diodes (LED) , whether or not assembled with other light-emitting diodes (LED); mounted piezo-electric crystals
8541.10	- Diodes, other than photosensitive or light-emitting diodes (LED)
8541.2	- Transistors, other than photosensitive transistors:
8541.21	- With a dissipation rate of less than 1 W
8541.29	- Other
8541.30	- Thyristors, diacs and triacs, other than photosensitive devices
8541.4	- Photosensitive semiconductor devices, including photovoltaic cells whether or not assembled in modules or made up into panels; light-emitting diodes (LED)
8541.41	- Light-emitting diodes (LED)
8541.42	- Photovoltaic cells not assembled in modules or made up into panels
8541.43	- Photovoltaic cells assembled in modules or made up into panels
8541.49	- Other
8541.5	- Other semiconductor devices:
8541.51	- Semiconductor-based transducers
8541.59	- Other
8541.60	- Mounted piezo-electric crystals
8541.90	- Parts

Table 20: HS2022 Chapter 94 Headings with Subheading classifications for relevant lighting products

SECTION XX	Miscellaneous manufactured articles
Chapter 94	Furniture; bedding, mattresses, mattress supports, cushions and similar stuffed furnishings; lamps and <b>lighting fittings</b> , not elsewhere specified or included; illuminated signs, illuminated name-plates and the like; prefabricated buildings
94.05	Lamps and <b>lighting fittings</b> including searchlights and spotlights and parts thereof, not elsewhere specified or included; illuminated signs, illuminated name-plates and the like, having a permanently fixed light source, and parts thereof not elsewhere specified or included
9405.1	- Chandeliers and <b>other electric ceiling or wall lighting fittings</b> , excluding those of a kind used for lighting public open spaces or thoroughfares
9405.11	- <b>Designed for use solely with light-emitting diode (LED) light sources</b>
9405.19	- <b>Other</b>
9405.2	- Electric table, desk, bedside or floor-standing lamps
9405.21	- Designed for use solely with light-emitting diode (LED) light sources
9405.29	- Other
9405.30	- Lighting sets of a kind used for Christmas trees
9405.31	- Designed for use solely with light-emitting diode (LED) light sources
9405.39	- Other
9405.40	- Other electric lamps and <b>lighting fittings</b>
9405.11	- <b>Designed for use solely with light-emitting diode (LED) light sources</b>
9405.19	- <b>Other</b>
9405.50	- Non-electrical lamps and lighting fittings
9405.6	- Illuminated signs, illuminated name-plates and the like:
9405.61	- Designed for use solely with light-emitting diode (LED) light sources
9405.69	- Other
9405.9	- Parts:
9405.91	- Of glass
9405.92	- Of plastics
9405.99	- Other



For more information:  
[communication@unep.org](mailto:communication@unep.org)  
United Nations Avenue, Gigiri  
PO Box 30552, 00100  
Nairobi, Kenya

[unep.org](http://unep.org)